



The Solution Providers

Assembly Tools & Precision Fastening



Quality and performance on the toughest jobs

DC ELECTRIC NUTRUNNERS

Ingersoll Rand offers a complete range of DC fastening tools in straight, right angle and (a unique) push-to-start configurations.

Ingersoll Rand DC fastening tools have built in torque transducers. The torque delivered by the tool is dynamically measured by the transducer and through a closed loop micro processor control, the tool is shut off when the desired torque is achieved. Angle control is attained through a resolver interfaced with the closed loop system. Advance strategies such as fastening to yield are achieved through algorithms.

The new IR QE-IC series fastening systems are the realization of an investment in innovation and technology that promises and delivers an unparalleled level of performance. The new QE-IC systems perform dramatically better than existing closed-loop DC platforms in improving productivity, reducing cost of ownership and maintenance, and offering a proven means of tightening critical assemblies.

TOOL

Four motor platforms named the QE2, QE4, QE6 and QE8 include tools in angle, inline, push-to-start and pistol configurations.

Productivity

- Faster speeds at torque
- Improved accuracy with Sine Drive technology
- Programmable momentary switch
- Modular designs offer optimum flexibility

Ergonomics

- Lightweight design
- Compact package
- Comfortable grip surfaces and smooth contours
- Low-force trigger and rotary reverse switch
- Digital Link between tool and controller
- One-piece rugged chassis
- Improved gear and cable life
- Non-contacting switches



CPS2-CORD-3M (3 meter)
 CPS2-CORD-6M (6 meter)
 CPS2-CORD-10M (10 meter)
 CPS2-CORD-6M-90 (90 degree, 6 meter)

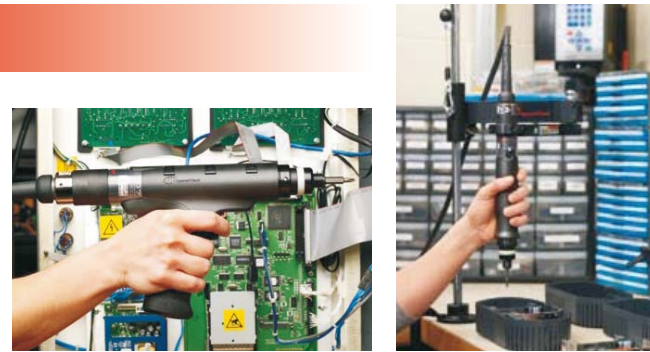

QE2 SERIES SCREW DRIVERS

Model	Torque Range Nm	Free Speed rpm	Weight kg	Drive Size in
QE2 INLINE PUSH-TO-START				
QE2TS002P11Q04	0.3 - 1.5	3,000	0.57	1/4"
QE2TS003P11Q04	0.6 - 3.0	2,450	0.57	1/4"
QE2TS005P11Q04	1.0 - 5.0	1,700	0.57	1/4"
QE2TS007P11Q04	1.3 - 6.5	1,250	0.57	1/4"
QE2TS010P11Q04	2.0 - 10.0	850	0.57	1/4"
QE2 INLINE LEVER START				
QE2SL002P10Q04	0.3 - 1.5	3,000	0.6	1/4"
QE2SL003P10Q04	0.6 - 3.0	2,450	0.6	1/4"
QE2SL005P10Q04	1.0 - 5.0	1,700	0.6	1/4"
QE2SL007P10Q04	1.3 - 6.5	1,250	0.6	1/4"
QE2SL010P10Q04	2.0 - 10.0	850	0.6	1/4"
QE2 INLINE LEVER + PUSH-TO-START				
QE2SP002P11Q04	0.3 - 1.5	3,000	0.6	1/4"
QE2SP003P11Q04	0.6 - 3.0	2,450	0.6	1/4"
QE2SP005P11Q04	1.0 - 5.0	1,700	0.6	1/4"
QE2SP007P11Q04	1.3 - 6.5	1,250	0.6	1/4"
QE2SP010P11Q04	2.0 - 10.0	850	0.6	1/4"
QE2 PUSH-TO-START PISTOL				
QE2PS002P11Q04	0.3 - 1.5	3,000	0.66	1/4"
QE2PS003P11Q04	0.6 - 3.0	2,450	0.66	1/4"
QE2PS005P11Q04	1.0 - 5.0	1,700	0.66	1/4"
QE2PS007P11Q04	1.3 - 6.5	1,250	0.66	1/4"
QE2PS010P11Q04	2.0 - 10.0	850	0.66	1/4"
QE2 TRIGGER START PISTOL				
QE2PT002P10Q04	0.3 - 1.5	3,000	0.66	1/4"
QE2PT003P10Q04	0.6 - 3.0	2,450	0.66	1/4"
QE2PT005P10Q04	1.0 - 5.0	1,700	0.66	1/4"
QE2PT007P10Q04	1.3 - 6.5	1,250	0.66	1/4"
QE2PT010P10Q04	2.0 - 10.0	850	0.66	1/4"
QE2 TRIGGER + PUSH-TO-START PISTOL				
QE2PP002P11Q04	0.3 - 1.5	3,000	0.66	1/4"
QE2PP003P11Q04	0.6 - 3.0	2,450	0.66	1/4"
QE2PP005P11Q04	1.0 - 5.0	1,700	0.66	1/4"
QE2PP007P11Q04	1.3 - 6.5	1,250	0.66	1/4"
QE2PP010P11Q04	2.0 - 10.0	850	0.66	1/4"
QE2 ANGLE LEVER START				
QE2AL005PA3Q04	1 - 5	1,590	0.95	1/4"
QE2AL005PA3H04	1 - 5	1,590	0.95	1/4"
QE2AL007PA3Q04	1.4 - 7	1,100	0.95	1/4"
QE2AL007PA3H04	1.4 - 7	1,100	0.95	1/4"
QE2 ANGLE LEVER START				
QE2AL010PA3S04	2 - 10	730	0.95	1/4"
QE2AL010PA3Q04	2 - 10	730	0.95	1/4"
QE2AL010PA3H04	2 - 10	730	0.95	1/4"
QE2AL015PA3Q04	3 - 15	560	0.95	1/4"
QE2AL015PA3H04	3 - 15	560	0.95	1/4"

Models shown above are a representative selection of our extensive range. Please contact Ingersoll Rand for details on additional models.

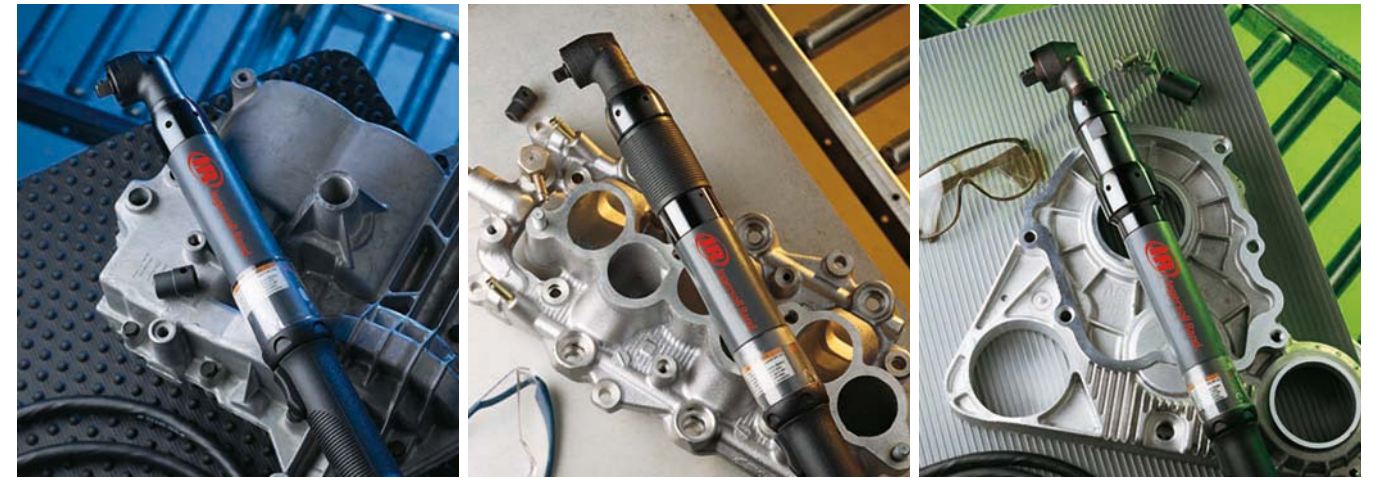

QE4 System

QE6 System

QE8 System



QE4 / QE6 / QE8 SERIES

Model	Max. Torque Range Nm	Recmd. Torque Range Nm	Free Speed rpm	Weight kg	Drive Size in	Bolt Size mm
QE ANGLE						
QE4AT013PA2H04	13	3-10	1200	1.3	1/4 Hex	M5-M6
QE4AT020PA2S06	20	4-16	820	1.3	3/8	M6-M8
QE4AT027PA4S06	27	5-22	600	1.3	3/8	M8
QE4AT034PA4S08	34	7-27	470	1.3	1/2	M8
QE6AT030PA4S08	30	6-24	1230	1.9	1/2	M8
QE6AT040PA4S08	40	8-32	910	1.9	1/2	M8
QE6AT055PA5S08	55	11-44	650	1.9	1/2	M10
QE6AT080PA5S08	80	16-64	440	1.9	1/2	M10
QE8AT065PA5S08	65	13-52	1200	2.9	1/2	M10
QE8AT070PA5S08	70	14-56	1100	2.9	1/2	M10
QE8AT090PA6S08	90	18-72	850	2.9	1/2	M10
QE8AT115PA6S08	115	23-92	660	2.9	1/2	M12
QE8AT150PA6S08	150	30-120	510	2.9	1/2	M12-M14
QE8AT225PA7S12	225	45-180	310	4.1	3/4	M16
QE8AT400FA8S12	400	80-320	170	6.0	3/4	M18
QE INLINE						
QE4ST010B41Q04	10	2-8	1820	1.2	1/4 Hex	M4-M5
QE4ST015B41Q04	15	3-11	1220	1.2	1/4 Hex	M5-M6
QE4ST020B41S06	20	4-16	900	1.2	3/8	M6-M8
QE4ST025B41S06	25	5-20	710	1.2	3/8	M6-M8
QE6ST020F61S06	20	4-16	1840	2.1	3/8	M6-M8
QE6ST028F61S06	28	6-22	1360	2.1	3/8	M8
QE6ST033F61S08	33	7-26	1130	2.1	1/2	M8
QE6ST050F61S08	50	10-40	760	2.1	1/2	M10
QE8ST055F61S08	55	11-44	1470	3.0	1/2	M10
QE8ST070F61S08	70	14-56	1470	3.0	1/2	M10
QE8ST090F61S08	90	18-72	1160	3.0	1/2	M10
QE8ST150F61S08	150	30-120	500	3.4	1/2	M12-M14
QE8ST230F62S12	230	45-185	340	5.5	3/4	M16
QE PUSH TO START						
QE4TS010R11Q04	10	2-8	1820	1.2	1/4 Hex	M4-M5
QE4TS015R11S06	15	3-12	1220	1.2	3/8	M5-M6
QE4TS020R11S06	20	4-16	900	1.2	3/8	M6-M8
QE4TS025R11S06	25	5-20	710	1.2	3/8	M6-M8
QE PISTOL GRIP						
QE4PT010P10Q04	10	2-8	1820	1.2	1/4 Hex	M4-M5
QE4PT015P10S04	15	3-12	1220	1.2	3/8	M5-M6
QE4PT020P10S06	20	4-16	900	1.2	3/8	M6-M8
QE4PT025P10S06	25	5-20	710	1.2	3/8	M6-M8

QM SERIES SPINDLES

QM Series DC spindles are the workhorse of your multispindle application. With four platforms that provide broad torque and speed coverage, Ingersoll-Rand QM spindles deliver the highest level of performance, durability, and reliability in the industry. The QM3, QM5, QM7, and QM9 platforms are so durable, in fact, that we stopped testing them after three million fault-free cycles.

Model	Max. Torque Range Nm	Rec. Torque Range Nm	Speed rpm	Drive Size in
QM3S() 008()	8	2-6	1,382	3/8" or 1/2"
QM3S() 012()	12	3-10	927	3/8" or 1/2"
QM3S() 016()	16	4-13	686	3/8" or 1/2"
QM3S() 020()	20	4-16	545	3/8" or 1/2"
QM5S() 035()	35	7-28	590	3/8" or 1/2"
QM5S() 055()	55	11-44	507	3/8" or 1/2"
QM5S() 090()	90	18-72	280	1/2"
QM7S() 190()	190	38-152	273	3/4" or 1/2"
QM7S() 220()	220	44-176	233	3/4"
QM9S() 315()	315	63-250	278	3/4" or 1"
QM9S() 435()	435	87-348	203	3/4" or 1"
QM9S() 520()	520	104-416	170	3/4" or 1"
QM9S() 650()	650	130-520	136	1"
QM9S() 01K()	1000	200-800	51	1"



INSIGHT IC12D/IC12M CONTROLLERS

The new Ingersoll Rand Insight IC1D controllers give you full closed-loop control in an industry-leading compact size. With features like a VGA colour display and intuitive programming interface, the IC1D units provide unmatched performance and value.



- Power switch is enclosed in rubber boot for protection.
- Parameter Transfer Key (PTK) enables quick upload, recovery, transfer, and storage of configuration sets.
- Removable cover provides easy access to connections and terminals, even when the unit is installed.
- Program up to eight basic fastening configurations and access all 256 stored in memory.
- Professional 1/4 VGA 216 -colour display is visible from 20 ft (6.1 m).
- Standard Ethernet and I/O connections optimize communication and line integration.
- The controller has 1,000 cycles of end-of-run automatic data storage.
- Dual-mode power supply : 90 - 120 VAC and 200 - 240 VAC.
- Internal maximum ambient operating temperatures of 0°- 50°C (32°- 122°F) ensure reliable use in demanding conditions without risk of overheating.
- Easy installation and set-up with convenient bracketing system.
- Comfortable and tactile membrane facilitates easy programming and screen navigation.
- Extruded aluminium cooling fins.

IC12D SELECTION GUIDE

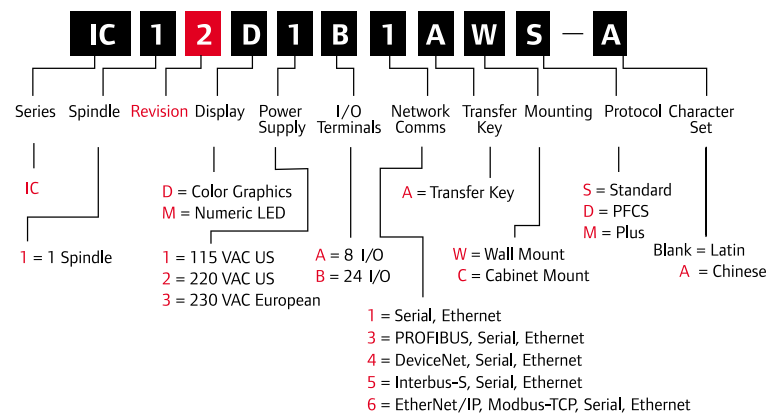

IC12D



IC12M

ICS SOFTWARE

Paired with an Insight IC12D or IC12M controller and a computer, our ground breaking ICS Software Suite makes it possible to more precisely control and monitor your fastening process. Optimizing your system is as simple as selecting one of four packages.

ICS CONNECT

ICS Connect provides operators with the ability to access and program basic fastening strategies, as well as view cycle data with a single IC12D or IC12M controller via a one-to-one Ethernet connection, ICS Connect is supplied standard with all IC12D and IC12M controllers.

ICS NETWORK

ICS Network enables programming of multiple IC12D and IC12M controllers connected through a local area network (LAN) or direct connection. This option also allows operators to program advanced fastening strategies including yield and prevailing torque control.

ICS MULTISYNC

The ICS MultiSync package facilitates set-up and control of multispindle systems consisting of up to 100 spindles in groups of up to 40 spindles. This package also offers advanced multispindle fastening strategies, remote monitoring, and data archiving.

ICS ENTERPRISE

ICS Enterprise offers advanced programming and management of a network of upto 500 IC12D or IC12M controllers using QE tools, QM spindles, or multispindle systems. Also enables ODBC-compliant database archiving, searching, and statistics processing.

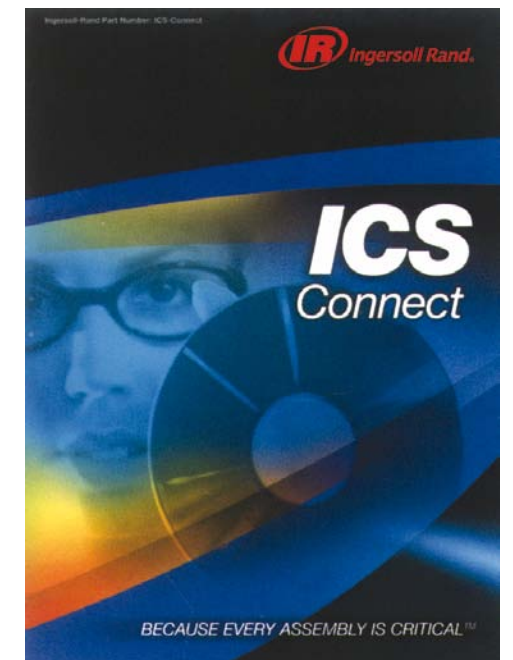
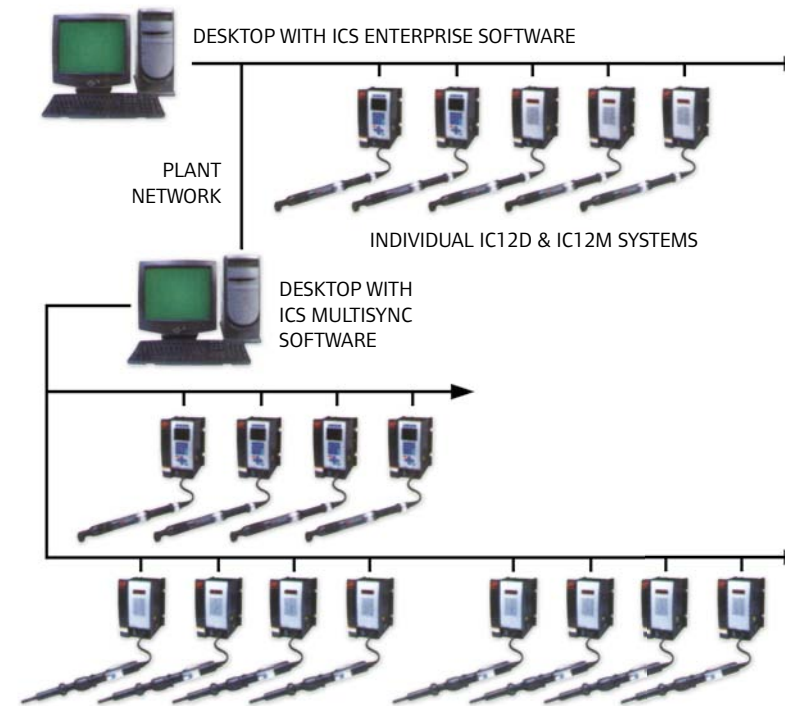

90° Tool Cable
P/N GEA40-CORD-COM-90



Socket Tray (4 position)
P/N 171122403005



Remote Light Alarm Box
P/N 175122403001



Heavy Duty Tool Arm

Part Number	Extension length
501100003102	120 mm
501100003101	300 mm
501100003002	600 mm

QX SERIES CORDLESS PRECISION SCREWDRIVER

Not Just Torque Control...Total Control

Control

- Multi-function display module and password protected keypad offer quick setup and visual feedback—right on the tool
- Eight user-programmable torque/angle/speed configurations allow one tool to do the job of up to eight, reducing tool costs and workspace clutter
- Closed-loop transducer control ensures quick assembly, precise torque and accurate, traceable results

Comfort

- Compact, cordless assembly tool gives you the freedom to work without constraints
- Lightweight, low-reaction, ergonomically balanced design maximizes operator comfort
- Safe and clean operation – no cords, air hoses or brush dust

Communication

- Wireless communication option delivers process control with I/O, automatic configuration switching and real-time data archiving for up to 10 tools via Process Communication Module (PCM)
- Plant-wide networking manages both process control inputs and feedback data using Ethernet, Fieldbus or I/O, complete with data archiving



Model Key and Specifications

Q	X	2	P	T	08	P	Q4
Series QX	Comms X = Radio C = USB Only	Motor 2	Style P = Pistol	Actuation T = Trigger	Maximum Torque 04 = 4 Nm 08 = 8 Nm 12 = 12 Nm	Mounting P = Standard	Drive Q4 = 1/4" Quick Change S4 = 1/4" Square S6 = 3/8" Square

Model	in-lbs (Nm)	rpm	lbs (kg)*	in (mm)	in (mm)	in	v	Communication			
QX SERIES											
QXX2PT04PQ4	7 - 35 (0.8 - 4)	1,500	2.00	0.91	8.48	215.4	0.8 - 1.0	20.3 - 26.0	1/4" ☉	20V Li-ion	Wireless Enabled
QXX2PT04PS4	7 - 35 (0.8 - 4)	1,500	2.00	0.91	8.20	208.3	0.8 - 1.0	20.3 - 26.0	1/4" □	20V Li-ion	Wireless Enabled
QXX2PT04PS6	7 - 35 (0.8 - 4)	1,500	2.00	0.91	8.35	212.0	0.8 - 1.0	20.3 - 26.0	3/8" □	20V Li-ion	Wireless Enabled
QXX2PT08PQ4	14 - 70 (1.6 - 8)	1,150	2.00	0.91	8.48	215.4	0.8 - 1.0	20.3 - 26.0	1/4" ☉	20V Li-ion	Wireless Enabled
QXX2PT08PS4	14 - 70 (1.6 - 8)	1,150	2.00	0.91	8.20	208.3	0.8 - 1.0	20.3 - 26.0	1/4" □	20V Li-ion	Wireless Enabled
QXX2PT08PS6	14 - 70 (1.6 - 8)	1,150	2.00	0.91	8.35	212.0	0.8 - 1.0	20.3 - 26.0	3/8" □	20V Li-ion	Wireless Enabled
QXX2PT12PQ4	21 - 106 (2.4 - 12)	750	2.00	0.91	8.48	215.4	0.8 - 1.0	20.3 - 26.0	1/4" ☉	20V Li-ion	Wireless Enabled
QXX2PT12PS4	21 - 106 (2.4 - 12)	750	2.00	0.91	8.20	208.3	0.8 - 1.0	20.3 - 26.0	1/4" □	20V Li-ion	Wireless Enabled
QXX2PT12PS6	21 - 106 (2.4 - 12)	750	2.00	0.91	8.35	212.0	0.8 - 1.0	20.3 - 26.0	3/8" □	20V Li-ion	Wireless Enabled
QXC2PT04PQ4	7 - 35 (0.8 - 4)	1,500	2.00	0.91	8.48	215.4	0.8 - 1.0	20.3 - 26.0	1/4" ☉	20V Li-ion	Via USB Cable
QXC2PT04PS4	7 - 35 (0.8 - 4)	1,500	2.00	0.91	8.20	208.3	0.8 - 1.0	20.3 - 26.0	1/4" □	20V Li-ion	Via USB Cable
QXC2PT04PS6	7 - 35 (0.8 - 4)	1,500	2.00	0.91	8.35	212.0	0.8 - 1.0	20.3 - 26.0	3/8" □	20V Li-ion	Via USB Cable
QXC2PT08PQ4	14 - 70 (1.6 - 8)	1,150	2.00	0.91	8.48	215.4	0.8 - 1.0	20.3 - 26.0	1/4" ☉	20V Li-ion	Via USB Cable
QXC2PT08PS4	14 - 70 (1.6 - 8)	1,150	2.00	0.91	8.20	208.3	0.8 - 1.0	20.3 - 26.0	1/4" □	20V Li-ion	Via USB Cable
QXC2PT08PS6	14 - 70 (1.6 - 8)	1,150	2.00	0.91	8.35	212.0	0.8 - 1.0	20.3 - 26.0	3/8" □	20V Li-ion	Via USB Cable
QXC2PT12PQ4	21 - 106 (2.4 - 12)	750	2.00	0.91	8.48	215.4	0.8 - 1.0	20.3 - 26.0	1/4" ☉	20V Li-ion	Via USB Cable
QXC2PT12PS4	21 - 106 (2.4 - 12)	750	2.00	0.91	8.20	208.3	0.8 - 1.0	20.3 - 26.0	1/4" □	20V Li-ion	Via USB Cable
QXC2PT12PS6	21 - 106 (2.4 - 12)	750	2.00	0.91	8.35	212.0	0.8 - 1.0	20.3 - 26.0	3/8" □	20V Li-ion	Via USB Cable

* Weight without battery, battery sold separately

QX SERIES PROCESS COMMUNICATION MODULE (PCM)

Each Process Communication Module provides wireless data transmission for upto 10 tools or enables tool integration into plant process control systems.

Power Cord	BC10-CORD-US	IC-PCM-1-IN	IC-PCM-2-IN
Tool Connections	Wireless tool connections	10	1
Software	ICS Connect software	•	•
Power Supply	120V AC input, 5V DC output	•	•
Communication	Ethernet to ICS	•	•
Fieldbus Options	Ethernet/IP, DeviceNet, Interbus-S, Profibus, Modbus-TCP		•
Protocols	Open Protocol, Ethernet EOR, Serial EOR		•
Printers/Devices	Serial RS232, bar code, label printing		•
I/O	8 inputs/8 outputs, with behaviour assignable through ICS software, operates at 24V DC		•
I/O Power Supply	120V AC input, 24V DC output		•
Indicators	Power ON, System Ready, Wireless Activity, Ethernet Activity	•	•
Ambient Operating Conditions	0-50°C, 20/90% non-condensing humidity	•	•
Enclosure	IP52 mounted in upright vertical position	•	•
System Weight	3.0 lb (1.4 kg)	•	•
Overall Dimensions	11.5 in x 4.1 in x 8.3 in 291 mm x 103 mm x 210 mm	•	•



Process Communication Module
IC-PCM-2-IN

For Plant-Wide Productivity... Get Connected
Ingersoll Rand doesn't just give you unprecedented technology. We give you total control over that technology...control that translates to maximum productivity.

Real-Time Monitoring



Data Archiving

Process Control

ASSEMBLY AUTOMATION

MULTI SPINDLE NUTRUNNERS

Multi Spindle Nutrunners require a thorough understanding of customer requirements and the mating of equipment with the customer's assembly lines. Functions at which Ingersoll Rand's expertise has been demonstrated through an installation base of several thousand spindles.

Some of the assembly solutions manufactured recently by Ingersoll Rand are shown on this page.

PNEUMATIC MULTI SPINDLE NUTRUNNERS

Pneumatic Multi Spindle Nutrunners are recommended for less critical joints. These units are available in stall, minimum torque sensing and shut off versions.

DC MULTI SPINDLE NUTRUNNERS

DC Nutrunner are recommended for simultaneous and precision tightening, can do advance fastening strategies such as Angle Control, Yield Control Retorque, customise sequence tightening etc.



4 Spindle air Nutrunner for Cylinder Head Tightening



7 Spindle air Nutrunner for Crank Case LH & RH Tightening



12 Spindle DC Nutrunner for Cylinder Head Tightening



18 Spindle DC Nutrunner for Cylinder Head Tightening



2 Spindle DC Nutrunner for Connecting Rod Tightening

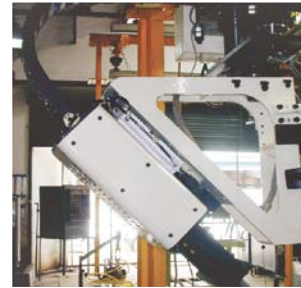

3 Spindle DC Nutrunner for Spark Plug Tightening



Single Spindle with Servo Controlled X-Y Axis Movement for Auto Sequenced Tightening of Cylinder Head



8 Spindle Machine Mounted DC Nutrunner for Fully Automated Operation (tact time = 6 sec.) for Compressor Head Tightening



C-Frame Mounted 8 Spindle for Intake Manifold Tightening



4 Spindle for Wheel Nut Tightening



IC12M

IC12D

Features of Ingersoll Rand Controllers for Fixtured Applications

- Modular plug and play construction.
- The programming is user friendly and does not need any special skills.
- Multi level password protection to prevent unauthorised program access.
- Fault indication & easy trouble shooting
- Inbuilt tightening strategies
 - Torque Control
 - Angle Control
 - Yield Control
 - Prevailing Torque Control
 - Retorque
 - Back-out Control
 - Drag Torque
- Upgradable software

ANGLE NUTRUNNERS

There's much more to an assembly application than merely putting wrench to bolt. It's an intricate matter of linking tool users and fasteners to deliver an uncompromised combination of accuracy, durability, speed, and ergonomics.

The solution: Ingersoll Rand precision air nutrunners. Our newly designed precision air nutrunners are compact, lightweight, quiet, and durable enough for the toughest high-volume applications, yet still deliver the speed and accuracy you need. The QA4, QA6, and QA8 Series tools are easy to maintain – which means less downtime – and are fully configurable in straight or angle configurations, shut-off or stall, with fixed or floating spindles, and in a variety of drive sizes upto 225 Nm.

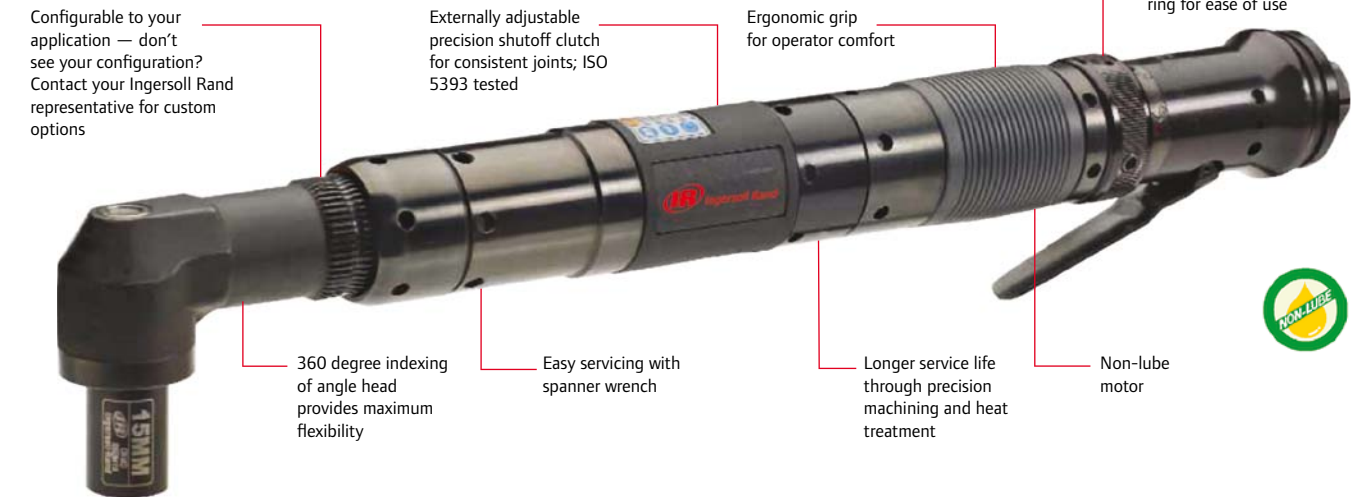

ANGLE SHUTOFF NUTRUNNERS

Model	Sq. Drive	@ 90 psi / 620 kPa		Weight kg	Length mm	mm		Air Consumption
		Torque Range Nm	rpm			mm	mm	
QA4 Series Shut-off								
QA4AALS011NP25S06W	3/8"	5 – 11	1025	1.44	342	33	13	27
QA4AALS015NP25S06W	3/8"	7 – 15	800	1.44	342	33	13	27
QA4AALS020NP25S06W	3/8"	10 – 20	625	1.44	342	33	13	27
QA4AALS020NP28S06W	3/8"	10 – 20	625	1.52	363	35	14	27
QA4AALS030NP28S06W	3/8"	15 – 30	425	1.52	363	35	14	27
QA4AALS040NP35S06W	3/8"	20 – 40	325	1.81	395	44	18	27
QA4AALS040NP35S08W	1/2"	20 – 40	325	1.81	395	44	18	27
QA4AALS055NP35S08W	1/2"	25 – 55	200	2.04	418	44	18	27
QA6 Series Shut-off								
QA6AALS030NP35S06W	3/8"	15 – 30	580	2.29	429	44	18	36
QA6AALS040NP35S06W	3/8"	20 – 40	430	2.29	429	44	18	36
QA6AALS040NP35S08W	1/2"	20 – 40	430	2.30	429	44	18	36
QA6AALS055NP35S08W	1/2"	25 – 55	320	2.30	429	44	18	36
QA6AALS070NP43S08W	1/2"	35 – 70	225	2.30	422	45	22	36
QA6AALS090NP43S08W	1/2"	45 – 90	185	2.30	422	45	22	36
QA8 Series Shut-off								
QA8AALS040NP35S06W	3/8"	20 – 40	570	2.44	453	44	18	41
QA8AALS040NP35S08W	1/2"	20 – 40	570	2.45	453	44	18	41
QA8AALS055NP35S08W	1/2"	25 – 55	425	2.45	453	44	18	41
QA8AALS070NP43S08W	1/2"	35 – 70	320	2.45	445	45	22	41
QA8AALS090NP43S08W	1/2"	45 – 90	255	2.45	445	45	22	41
QA8AALS115NP48S08W	1/2"	70 – 115	200	2.79	452	50	25	41
QA8AALS150NP48S08W	1/2"	75 – 150	145	3.12	489	50	25	41
QA8AALS200NF56S12W	3/4"	100 – 200	110	4.02	508	53	30	41

Performance figures are at 620 kPa (90 psi) air pressure

ANGLE STALL AIR NUTRUNNERS

Model	Sq. Drive in	@90 psi/620 kPa		@77 psi/530 kPa		Weight kg	Length mm	mm		Air Consumption
		Torque Range Nm	rpm	Torque Range Nm	rpm			mm	mm	
QA4 Series										
QA4AALD011NP25S06W	3/8"	11	1025	10	1.12	283	33	13	27	
QA4AALD015NP25S06W	3/8"	15	800	13	1.12	283	33	13	27	
QA4AALD020NP25S06W	3/8"	20	625	17	1.12	283	33	13	27	
QA4AALD030NP28S06W	3/8"	30	425	26	1.2	283	35	14	27	
QA4AALD040NP35S06W	3/8"	40	325	34	1.48	336	44	18	27	
QA4AALD055NP35S08W	1/2"	55	200	46	1.76	359	44	18	27	
QA6 Series										
QA6AALD030NP35S06W	3/8"	30	580	27	2.11	429	44	18	36	
QA6AALD040NP35S06W	3/8"	40	430	35	2.11	429	44	18	36	
QA6AALD040NP35S08W	1/2"	40	430	35	2.12	429	44	18	36	
QA6AALD055NP35S08W	1/2"	55	320	49	2.12	429	44	18	36	
QA6AALD070NP43S08W	1/2"	70	225	62	2.12	422	45	22	36	
QA6AALD090NP43S08W	1/2"	90	185	80	2.12	422	45	22	36	
QA8 Series										
QA8AALD040NP35S06W	3/8"	40	570	35	2.26	453	43.5	18	41	
QA8AALD040NP35S08W	1/2"	40	570	35	2.27	453	43.5	18	41	
QA8AALD055NP35S08W	1/2"	55	425	49	2.27	453	43.5	18	41	
QA8AALD070NP43S08W	1/2"	70	320	62	2.27	445	44.7	22	41	
QA8AALD090NP43S08W	1/2"	90	255	80	2.27	445	44.7	22	41	
QA8AALD115NP48S08W	1/2"	115	200	102	2.61	452	50	25	41	
QA8AALD150NP48S08W	1/2"	150	145	133	2.94	489	50	25	41	
QA8AALD200NF56S12W	3/4"	200	110	178	3.84	508	53.2	30	41	
QA8AALD225NF56S12W	3/4"	225	90	222	3.84	508	53.2	30	41	

*Note: Highest recommended torque setting for assembly line applications. Exceeding the highest recommended torque setting may result in reduced tool life.

INLINE NUTRUNNERS

Configurable to your application - don't see your configuration? Contact your Ingersoll Rand representative for custom options

Longer service life through precision machining and heat treatment

Precision shutoff clutch tested to 1 million cycles without failure

Ergonomic grip for operator comfort

Ideally positioned reverse ring for ease of use

Quiet operation



Easy servicing with spanner wrench

Externally adjustable precision shutoff clutch for consistent joints; ISO 5393 tested

Powerful non-lube motor



Standard 4" inline spindle provides 19 mm of float to accommodate faster rundown in fixtured applications

Multiple mounting flange options provide flexibility to customize the application (see below)

INLINE SHUTOFF AIR NUTRUNNERS

Model	Sq. Drive in	@90 psi/620 kPa		Weight kg	Length mm	mm	Air Consumption
		Torque Range Nm	rpm				
QA4 Series Shut-off							
QA4ASLS012NP41S06W	3/8"	6 - 12	1050	1.46	464	21	27
QA4ASLS015NP41S06W	3/8"	7 - 15	850	1.46	464	21	27
QA4ASLS020NP41S06W	3/8"	10 - 20	600	1.46	464	21	27
QA4ASLS027NP41S06W	3/8"	14 - 27	450	1.46	464	21	27
QA4ASLS046NP41S06W	3/8"	20 - 46	250	1.69	478	23	27
QA4ASLS046NP41S08W	1/2"	20 - 46	250	1.71	478	23	27
QA6 Series Shut-off							
QA6ASLS025NP41S06W	3/8"	12 - 25	720	2.3	478	20	36
QA6ASLS030NP41S06W	3/8"	15 - 30	605	2.3	478	20	36
QA6ASLS040NP41S06W	3/8"	20 - 40	450	2.3	478	20	36
QA6ASLS055NP41S08W	1/2"	25 - 55	325	2.31	478	20	36
QA8 Series Shut-off							
QA8ASLS040NP41S06W	3/8"	20 - 40	600	2.39	502	20	41
QA8ASLS040NP41S08W	1/2"	20 - 40	600	2.4	502	20	41
QA8ASLS055NP41S08W	1/2"	25 - 55	470	2.4	502	20	41
QA8ASLS070NP41S08W	1/2"	35 - 70	355	2.54	506	24	41
QA8ASLS090NP41S08W	1/2"	45 - 90	255	2.87	542	24	41
QA8ASLS115NF41S08W	1/2"	70 - 115	215	3.4	541	51	41
QA8ASLS150NF41S08W	1/2"	75 - 150	165	3.4	541	51	41
QA8ASLS180NF41S08W	1/2"	90 - 180	140	3.4	541	51	41



REMOTE START

Configurable to your application - don't see your configuration? Contact your Ingersoll Rand representative for custom options

Standard flange provides secure fixturing point

Longer service life through precision machining and heat treatment

Powerful non-lube motor

Compact, slim design provides easy fixturing

Easy servicing with spanner wrench

Externally adjustable precision shutoff clutch for consistent joints; ISO 5393 tested

Standard 4" inline spindle provides 19 mm of float to accommodate faster rundown in fixture applications

Precision shutoff clutch tested to 1 million cycles without failure



Secondary exhaust (reverse)

Primary exhaust

Inlet (forward)

Cycle count air port provides tool shutoff signal

REMOTE START SHUTOFF AIR NUTRUNNERS

Model	Sq. Drive in	@90 psi/620 kPa		Weight kg	Length mm	mm	Air Consumption
		Torque Range Nm	rpm				
QA4 Series Remote Start -							
QA4ASRS012NF41S06W	3/8"	6 - 12	1050	1.61	451	21	27
QA4ASRS015NF41S06W	3/8"	7 - 15	850	1.61	451	21	27
QA4ASRS020NF41S06W	3/8"	10 - 20	600	1.61	451	21	27
QA4ASRS027NF41S06W	3/8"	14 - 27	450	1.61	451	21	27
QA4ASRS046NF41S06W	3/8"	20 - 46	250	1.84	465	23	27
QA4ASRS046NF41S08W	1/2"	20 - 46	250	1.84	465	23	27
QA6 Series Remote Start -							
QA6ASRS025NF41S06W	3/8"	12 - 25	700	2.61	454	34	36
QA6ASRS030NF41S06W	3/8"	15 - 30	585	2.61	454	34	36
QA6ASRS040NF41S06W	3/8"	20 - 40	435	2.61	454	34	36
QA6ASRS055NF41S08W	1/2"	25 - 55	315	2.62	454	34	36
QA8 Series Remote Start -							
QA8ASRS040NF41S06W	3/8"	20 - 40	540	2.73	478	34	41
QA8ASRS040NF41S08W	1/2"	20 - 40	540	2.74	478	34	41
QA8ASRS055NF41S08W	1/2"	25 - 55	425	2.74	478	34	41
QA8ASRS070NF41S08W	1/2"	35 - 70	320	3.09	482	43	41
QA8ASRS090NF41S08W	1/2"	45 - 90	230	3.42	518	43	41
QA8ASRS115NF41S08W	1/2"	70 - 115	195	3.64	517	51	41
QA8ASRS150NF41S08W	1/2"	75 - 150	150	3.64	517	51	41
QA8ASRS180NF41S08W	1/2"	90 - 180	125	3.64	517	51	41

REACTION BAR

STANDARD REACTION BAR

Reaction bars are recommended with angle nut runner (QA & QE Series) where torque is more than 40 Nm. Reaction bar with angle nut runner is the most effective and economic solution of taking reaction out of an operator hand.

Standard reaction bar can be used for applications where torque requirement with angle nutrunner is more than 40 Nm and less than 150 Nm.

Reaction Bar Assembly GEA 15 - K48W (Consist of a clamp and a Rod)

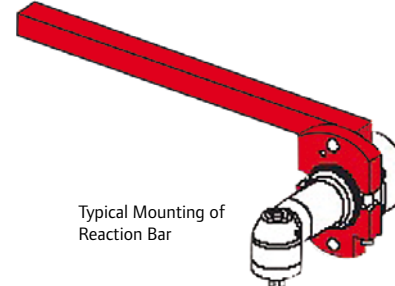

Typical Mounting of Reaction Bar



Clamp



Rod

Performance figures are at 620 kPa (90 psi) air pressure

QUICK MULTIPLES

Quick multiples consist of pre-engineered modular component designs that allow quick quoting, manufacture, and delivery of more common fixtured fastening solutions for up to six spindles. Depending on the application, vertical, horizontal, or rotating horizontal systems can be assembled with easily customized handles, displays, fixtures, and integrated handling devices for optimal operator ergonomics and performance.

- Pre-Engineered Modular designs
- Quick Quoting and Delivery
- Vertical, Horizontal & Rotating Horizontal designs
- Upto 6 DC or Air spindles per system
- Configurable handle options configurable operator interface module
- Used with world class QE, QM & QA spindles and ICD & M Controllers Integrated handling devices

Modular design provides for easy customization of open- or closed-frame fixtures in vertical, horizontal, or rotating horizontal configurations.

Mounts are available in several options that adjust to give operators the most ergonomic position, visibility, and control possible.

Handle module provides multiple switch options based on the application.

Customizable interface provides the control and feedback you desire. Standard LED display shows individual spindle and master OK/NOK signals.

Modular design offers flexibility for easy customization, rapid quotes, and lead-times.

World-class tools deliver accuracy and durability to maximize your line's productivity.

- QM and QE Series
- QA4, 6, 8 Series

Cable tray provides secure routing path, which keeps cables safe and out of the way, and reduces sharp bends.

Multiple suspension and torque reaction options:

- Balancers
- Torque tubes
- Articulating arms
- Custom devices
- Jib cranes
- Pneumatic suspension

Heavy-duty bearing delivers smooth rotation and adjustable stops for upto six spindles and provides for an ideal cable exit.

Circular handle allows rapid positioning of sockets on bolts.

Mounting plates can be quickly and easily machined to the exact job specifications.

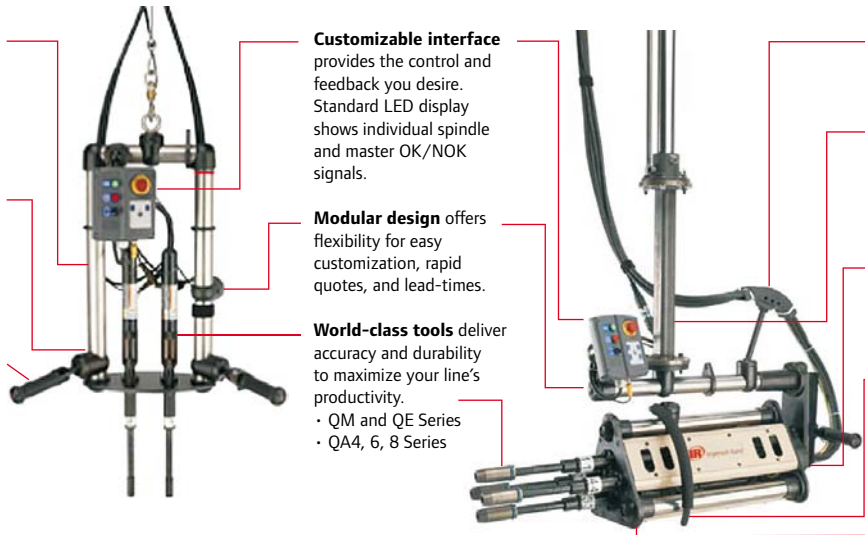

TORQUE TUBES

- Available in three torque capacities – 100 Nm, 250 Nm and 500 Nm
- Linear bearings for effortless vertical travel and maintenance-free operation
- Lifting capacities of 27 and 182 Kg
- Four Delrin wheels for torque reaction and side loading in all directions
- Adjustable lengths every 2 inches to eliminate the need for extension tubes
- Available bolt-on attachments for tool holders and suspension

TORQUE TUBES

Model	Lift Nm	Capacity @		Travel mm
		100 psi kg	Weight lb (kg)	
IRZ-TT-100 SH	100	27	18	508
IRZ-TT-250SH	250	27	23	610
IRZ-TT-500*	500	182	75	914

*Carriage mount option only; custom tool holder required. Contact factory for details.

TOOL HOLDERS

Part Number	For Use With	Description	"D" Dimension mm(in)	Weight lb(kg)
52000	IR2-TT-100SH	Fixed (2 axis) horizontal/vertical	4.82 (122)	2.30 (0.90)
52100	IR2-TT-250SH	360° (3 axis) swivel	5.38 (136.7)	5.00 (2.27)

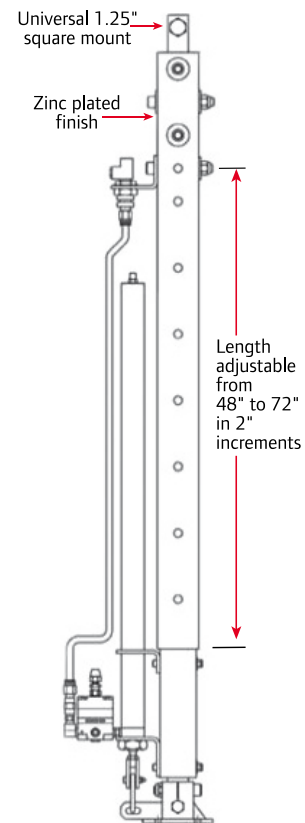
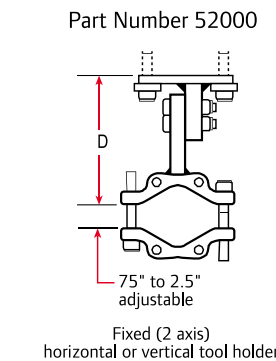
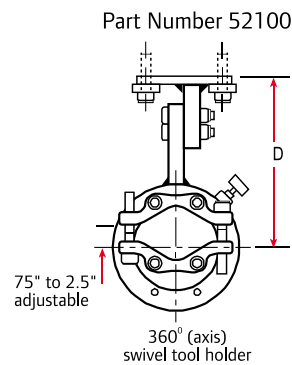

QTA TORQUE ARMS

Ingersoll Rand QTA bench-mounted torque reaction arms are constructed of lightweight aluminium and are available in a variety of torque capacities, ranging from 10 to 150 Nm. They include Ingersoll Rand spring-loaded, die-cast aluminium balancer for impressive strength and reduced weight.

Spring balancer adjusts easily and offers effortless vertical movement

Simple, proven design for trouble-free set-up and dependability

Anodized aluminium body delivers toughness in a lightweight design

Chrome plated pole paired with a self lubricating bearing provides unmatched durability

Cable or air line clamps keeps work area clear and organized (clamps are included with all QTA arms)

Adjustable reach for easy use and convenience when locating fasteners

Multiple tool holder options such as right angle, swivel and pistol grip (standard inline tool holder included with QTA models up to 100 NM capacity)

Custom tool holder options enable seamless Integration with Ingersoll Rand QA and QE tools

QTA Model shown

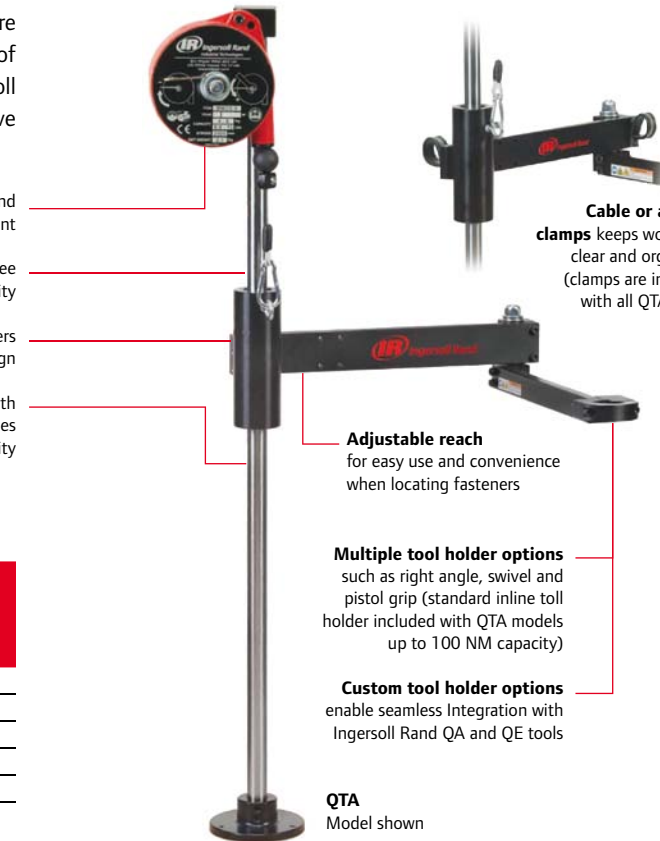

BENCH-MOUNTED QTA TORQUE ARMS*

Model	Max torque capacity Nm	Max weight capacity (kg)	Max working reach in (mm)	Vertical travel mm	Overall height mm
QTA010	10	1.20	381	330	706
QTA020	20	2.27	508	368	808
QTA040	40	2.95	635	445	1008
QTA100	100	3.63	762	445	1008
QTA150	150	4.54	1321	559	2000

NOTE: QTA150 is adjustable to mount to the floor or a bench and does not include a tool holder

FLOOR-MOUNTED TORQUE ARMS

When high torque fastening is required, Ingersoll Rand has two floor-mounted, air-enabled arms from which to choose with 270 and 475 Nm capacities.

Safety stop eliminates over extending arms

Generous arm length makes QTA ideal for assembly line applications

Custom tool holder options permit use with Ingersoll Rand QA and QE tools

Ingersoll Rand air regulator included with QTA270 and QTA475 arms

Adjustable height control delivers flexibility for virtually any application

Simple design ensures easy, effective set up and use

Solid, steel frame construction for rugged dependability

QTA270 model shown

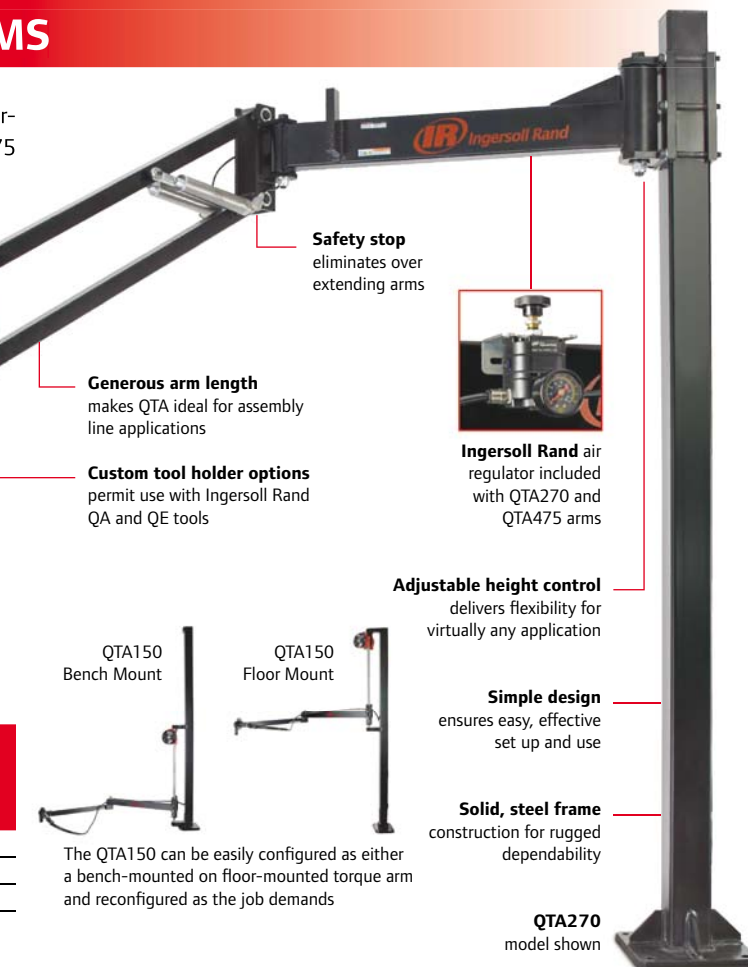

FLOOR-MOUNTED QTA TORQUE ARMS*

Model	Max torque capacity Nm	Max weight capacity (kg)	Max working reach in (mm)	Vertical travel mm	Overall height mm
QTA150	150	4.5	1321	559	2000
QTA 270	270	10.0	1524	477	2000
QTA 475	475	23.0	2007	590	2000

The QTA150 can be easily configured as either a bench-mounted or floor-mounted torque arm and reconfigured as the job demands

*Note: Arms above do not include tool holders (please refer Ingersoll Rand QTA catalogue for availability of various tool holders)

IQ^{V20} AND IQ^V SERIES CORDLESS TOOLS

As an industry leader for more than 100 years, Ingersoll Rand has a strong understanding of the jobs, impact tools are called on to perform. Our engineers know that a cordless impact has to do the job, do it fast, do it every time. Developed to perform, our cordless tools are best in industry which professional technicians will come to rely on in the shop and in the field.

Ingersoll Rand IQ^{V20} Series™ and IQ^V™ cordless tools are specifically designed for vehicle services, industrial maintenance and manufacturing applications. These tools make quick work of tough jobs that the professional technician does every day – something that until now, only an air tool could do.



Specifications	W5130		W5150	
Battery	BL2005	BL2010	BL2005	BL2010
Drive	3/8"	3/8"	1/2"	1/2"
Max Reverse Torque	180 ft-lb (245 Nm)	190 ft-lb (260 Nm)	180 ft-lb (245 Nm)	190 ft-lb (260 Nm)
Forward Torque Range	25-135 ft-lb (35-180 Nm)	25-140 ft-lb (35-190 Nm)	25-135 ft-lb (35-180 Nm)	25-140 ft-lb (35-190 Nm)
Blows per Minute	2,900 (bpm)	2,900 (bpm)	2,900 (bpm)	2,900 (bpm)
Maximum Free Speed	1,700 rpm	1,700 rpm	1,700 rpm	1,700 rpm
Length	6.6" (162 mm)	6.6" (162 mm)	6.6" (162 mm)	6.6" (162 mm)
Weight with Battery	3.6 lb (1.6 kg)	4.1 lb (1.9 kg)	3.6 lb (1.6 kg)	4.1 lb (1.9 kg)
Sound Level († Pressure, L)	91	91	91	91
Vibration Level	8.8 m/s ² (2.6 *K)	9.8 m/s ² (1.6 *K)	8.8 m/s ² (2.6 *K)	9.8 m/s ² (1.6 *K)

Specifications	W7150 standard anvil	W7250 2" extended anvil
Drive	1/2"	1/2"
Max Reverse Torque	780 ft-lb (1057 Nm)	780 ft-lb (1057 Nm)
Forward Torque Range	50 – 650 ft-lb (68 – 880 Nm)	50 – 650 ft-lb (68 – 880 Nm)
Nut-Busting Torque (NBT)	1,100 ft-lb	1,100 ft-lb
Blows per Minute	2,300	2,300
Maximum Free Speed	1,900 rpm	1,900 rpm
Length	9.4" (238 mm)	11.2" (285 mm)
Weight with Battery	6.8 lb (3.1 kg)	6.9 lb (3.1 kg)
Sound Level († Pressure, L)	89 dbA	89 dbA
Vibration Level	12.2 m/s ² (1.8 *K)	12.2 m/s ² (1.8 *K)

Specifications	W040	D550	D650
Drive	1/4"	1/2"	1/2"
Max Reverse Torque	54 Nm	62 Nm	73 Nm
Free Speed	0 - 2200 rpm	0 - 360/1300 rpm	0 - 360/1300 rpm
Weight with Battery	1.2	1.9	2.0
Voltage – volts	7.2	14.4	19.2

Sold separately: BC20 battery charger; BL072 Li-Ion for W040; BL144 Li-Ion for D550; BL192 Li-Ion for D650.



BATTERY AND CHARGERS

IQ^{V20} Series 20V
Battery Charger
BC1120

IQ^{V20} Series 20V, 3.0Ahr
Lithium-Ion Battery Pack
BL2010

IQ^{V20} Series 20V, 1.5Ahr
Lithium-Ion Battery Pack
BL2005



Lithium-Ion Battery and Charger

BL072 7.2 Volts
BL144 14.4 Volts
BL192 19.2 Volts
BC20



OIL PULSE TOOLS

Ingersoll Rand represents Uryu Seisaku Limited of Japan, the leaders in pulse tool technology. In pulse tools the mechanical impact mechanism is replaced by a hydraulic mechanism improving repeatability as well as reducing noise and vibration. The range encompasses straight, pistol grip and right angle configurations. Torque capabilities from 2.5Nm to 850Nm cover most assembly applications.

STRAIGHT TYPE

Model	Capacity (nominal bolt size) mm	Torque Range Nm	Free Speed rpm	Overall Length mm	Weight kg	Body Dia mm	Sq. Drive in	Average Air Cons. cfm	Noise Level dB(A)	Vib. Level m/sec ²
-------	---------------------------------	-----------------	----------------	-------------------	-----------	-------------	--------------	-----------------------	-------------------	-------------------------------

STANDARD OIL PULSE TOOLS

UX-450S	M5-M6	9-15	9500	234	0.80	22.0	3/8	7.0	67	2.2
UX-500S	M5-M6	15-25	9300	239	0.92	22.0	3/8	8.8	70	2.2
UX-612S	M6-M8	20-35	9300	248	1.00	23.3	3/8	11.1	75	2.2
UX-700S	M8	25-45	9000	244	1.27	26.5	3/8	12.3	78	2.2
UX-800S	M8-M10	35-60	9000	250	1.48	35.5	3/8	14.2	75	2.3
UX-900S	M10	45-75	7600	310	1.80	37.5	1/2	14.9	75	2.3
UX-1000S	M10-M12	50-95	6800	320	2.10	39.0	1/2	17.9	75	2.7
UX-1300S	M13-M14	80-130	6200	336	2.55	42.0	1/2	19.4	77	2.7
UXR-2000S	M18-M20	300-450	4200	340	7.0	94.0	3/4	31.6	85	3.2
UXR-2400S	M24	400-650	4000	385	11.0	110.0	1	35.2	85	3.2
UXR-3000S	M30	500-850	4400	455	13.0	124.0	1	37.1	85	3.2

AUTO SHUT OFF OIL PULSE TOOLS

ULT30SD	M4-M5	2.5-5.5	3700	221	0.75	21.5	1/4	7.0	66	1.1
ULT40S	M5	4.5-8.0	3600	218	0.80	22.5	3/8	7.0	70	1.0
ULT50S	M6-M8	7.0-15.5	5000	218	0.80	22.5	3/8	8.8	78	1.2
ULT60S	M8	15-32	5700	229	0.83	22.5	3/8	10.5	80	1.5
ULT70S	M8-M10	30-50	4700	239	0.95	23.5	3/8	12.3	80	-
UXR-T2400S	M24	360-650	3600	444	12.0	123	1	35.3	85	3.2
UXR-T3000S	M30	450-850	4400	477	14.5	124	1	37.1	85	3.2

ANGLE TYPE

Model	Capacity (nominal bolt size) mm	Torque Range Nm	Free Speed rpm	Overall Length mm	Weight kg	Angle Height mm	Sq. Drive in	Average Air Cons. cfm	Noise Level dB(A)	Vib. Level m/sec ²
-------	---------------------------------	-----------------	----------------	-------------------	-----------	-----------------	--------------	-----------------------	-------------------	-------------------------------

STANDARD OIL PULSE TOOLS

	C (mm)	H (mm)
UX-500C	15.0	59.5
UX-612C	16.0	59.5
UX-700C	16.0	62.0
UX-800C	18.0	70.0
UX-900C	18.0	70.0
UX-1000C	21.5	80.0

UX-500C	M5-M6	13-20	9300	270	1.28	59.5	3/8	8.8	82	18.0
UX-612C	M6	16-28	9800	283	1.38	59.5	3/8	11.2	85	30.0
UX-700C	M8	20-36	9500	273	1.67	62.0	3/8	12.3	85	5.6
UX-800C	M8-M10	29-43	9000	285	1.93	70.0	3/8	14.1	86	7.6
UX-900C	M10	35-55	7600	338	2.25	70.0	3/8	14.9	90	30.0
UX-1000C	M10-12	50-80	6800	365	3.05	80.0	1/2	17.9	90	10.0

CORDLESS TYPE

Model	Battery Models mm	Torque Range Nm	Free Speed rpm	Weight with Li-Ion kg	Voltage volts	Charger
-------	-------------------	-----------------	----------------	-----------------------	---------------	---------

CORDLESS OIL-PULSE TOOLS

UDBP-T40	UB111Li	4.5-8.0	4800	1.4	11.1	
UDBP-T50	UB111Li	6.5-13.0	4800	1.4	11.1	UBC
UDBP-T50(P)	UB111Li	7.0-15.0	4800	1.4	11.1	Battery
UDBP-T60	UB222Li	13.0-25.0	4800	1.7	22.2	Charger
UDBP-T60 (P)	UB222Li	15.0-28.0	4800	1.7	22.2	

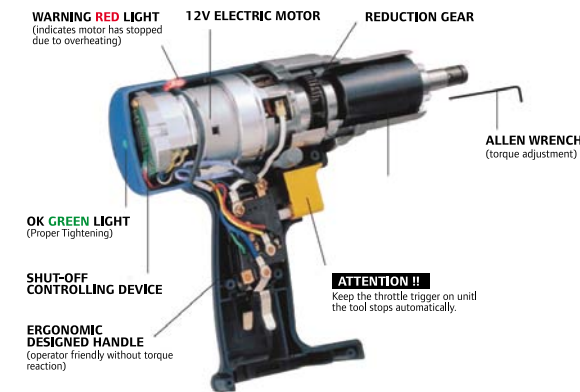

Performance figures are at 620 kPa (90 psi) air pressure

The Solution Providers | 15

OIL PULSE TOOLS

PISTOL TYPE

Model	Capacity (nominal bolt size) mm	Torque Range Nm	Free Speed rpm	Overall Length mm	Weight kg	Body Dia mm	Sq. Drive in	Average Air Cons. cfm	Noise Level dB(A)	Vib. Level m/sec ²
-------	---------------------------------	-----------------	----------------	-------------------	-----------	-------------	--------------	-----------------------	-------------------	-------------------------------

STANDARD OIL PULSE TOOLS										
UX-450	M5 - M6	9 - 15	9500	147	0.85	44	3/8	7.0	65	1.0
UX-500	M5-M6	15-25	9300	147	0.87	44	3/8	8.8	70	1.0
UX-612	M6-M8	20-35	9300	160	0.95	45	3/8	11.2	75	1.0
UX-700	M8	25 - 45	9000	169	1.38	51	3/8	12.3	72	0.7
UX-800	M8-M10	35-60	9000	175	1.10	56	3/8	14.1	75	1.0
UX-900	M10	45-75	7600	181	1.88	60	1/2	14.7	75	1.7
UX-1000	M10 - M12	50 - 95	6800	187	2.20	66	1/2	17.9	75	1.4
UX-1300	M12 - M14	80 - 130	6200	205	2.70	72	1/2	19.4	77	1.3
UX-1400	M14	100 - 160	5300	224	3.20	80	1/2	21.1	79	1.3
UX-1620	M14 - M16	120 - 190	5000	241	3.60	80	3/4	22.9	82	2.3
UXR-1820	M16 - M18	160 - 250	4600	242	4.10	84	3/4	26.3	84	3.2
UXR-2000	M18 - M20	300 - 450	4200	282	6.50	94	3/4	31.5	85	3.2

AUTO SHUT OFF OIL PULSE TOOLS										
UX-T700	M8	20 - 38	7500	187	1.46	56	3/8	10.5	72	0.7
UX-T800	M8 - M10	30 - 45	8300	196	1.80	56	3/8	12.3	75	1.0
UX-T900	M8 - M10	35 - 70	7000	202	2.00	60	1/2	16.0	75	1.7
UX-T1000	M10 - M12	50 - 90	6800	207	2.35	66	1/2	17.6	75	1.4
UX-T1300	M12 - M14	70 - 130	6200	225	2.80	72	1/2	19.4	77	1.3
UX-T1400	M14	100 - 160	5300	245	3.40	80	1/2	21.1	79	1.8
UXR-T1820	M16-M18	110 - 180	4400	270	4.50	84	3/4	24.7	84	3.2
UXR-T2000	M18-M20	200 - 400	4000	303	6.80	94	3/4	34.0	85	3.2

UL SERIES OIL PULSE TOOLS										
UL30	M5	6 - 12	5700	131	0.70		3/8	7.0	7.5	1.2
UL40	M5 - M6	13 - 22	6100	131	0.70		3/8	7.0	7.5	1.2
UL50	M6	22 - 35	6500	139	0.77		3/8	8.8	80	1.5
UL60	M8	32 - 50	6700	139	0.82		3/8	14.0	80	1.5
UL70	M8 - M10	40 - 65	5700	151	0.95		3/8	15.8	80	1.5
UL90	M10 - M12	60 - 100	5500	168	1.30		1/2	18.6	82	2.0
UL100	M12	80-130	5100	175	1.66		1/2	20.3	80	2.0

UAT & ULT SERIES AUTO SHUT OFF OIL PULSE TOOLS										
UAT40	M5	4.5-8.0	3800	162	0.92	24.5	9.5	0.25	75	0.54
UAT50	M6-M8	7.0-15.5	4600	162	0.92	24.5	9.5	0.3	78	0.55
UAT60	M8	11.1-23.7	6700	174	0.95	24.5	9.5	0.35	80	0.58
UAT70	M8-M10	22.2-40.7	6000	180	1.05	25.5	9.5	0.4	80	0.59
UAT80	M10-M12	33.3-46.6	5600	186	1.25	28.0	9.5	0.48	80	0.63
UAT90	M10-M12	37.0-62.9	5700	192	1.45	29.0	12.7	0.53	82	0.6
UAT100	M12	51.8-96.2	5200	199	1.70	31.5	12.7	0.55	82	0.6
ULT30D	M4	2.5 - 5.5	3600	162	0.77		1/4	7.0	75	1.0
ULT40	M5	4.5 - 8.0	3600	162	0.92		3/8	7.0	75	1.0
ULT50	M6 - M8	7.0 - 15.5	4400	162	0.92		3/8	8.8	78	1.2
ULT60	M8	15.0 - 32.0	6700	172	0.95		3/8	12.3	80	1.5
ULT70	M8 - M10	30.0 - 55.0	6000	178	1.05		3/8	14.0	80	1.5
ULT90	M10 - M12	50.0 - 85.9	5700	190	1.45		1/2	18.6	82	2.0
ULT100	M12	70.0 - 130.0	6200	197	1.70		1/2	19.3	82	2.0
ULT130	M14	110.0 - 150.0	4000	215	2.30		1/2	25.6	82	2.0
ULT150	M16	140 - 210	3700	238	2.90		3/4	24.5	82	2.0
ULT180	M16 - M18	170 - 260	3300	262	3.70		3/4	24.5	82	2.0

Model	Air Inlet	Hose Bore
UX-450, 500, 612 (S/C)	1/4" NPT	6 mm
UL & ULT series	1/4" NPT	8 mm
UX-700, 900, 1000, 1300 (S/C)	1/4" NPT	10 mm
UX-T800, 900, 1000, 1300	1/4" NPT	10 mm
UXR-1820, UXR-T2000	3/8" NPT	13 mm
UX-2400S, UXR-T3000S	1/2" NPT	13 mm

Pulse tools with quick change driver type anvil also available for models UX / UX-T 500 to 700
 UL / ULT40 to 60
 Add suffix D to model numbers
 Low pressure auto shut off tools also available. (UX-T & ULT Series)



UX-700



UX-T900



ULT70



UL90

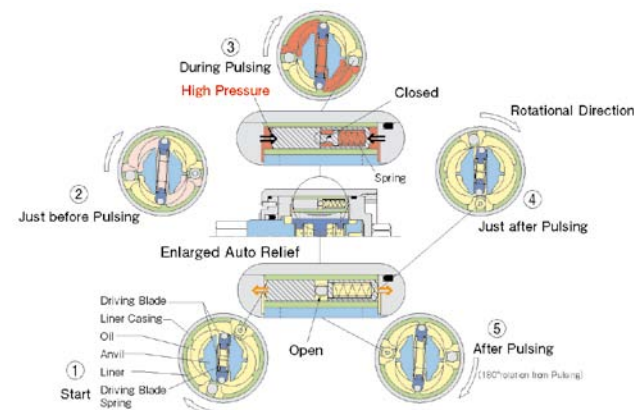

OPEN-END WRENCHES

Open-End wrenches are a fast & accurate solution for tube nut tightening. UOW-11 series are stall torque type tools and UOW-T60 series are mechanical shut-off type tools with external torque adjustment. An all gear drive mechanism provides precise torque, silent operation and longer tool life.

STRAIGHT TYPE

Model	Torque Range Nm	Free Speed rpm	Overall Length mm	Weight kg	Hex Size of Gear Socket () Standard mm	Average Air Cons. cfm
STALL TYPE						
UOW-11-10	12.74	400	295	1.4	8, 9, (10)	12.5
UOW-11-14	15.68	260	311	1.8	10, 11, 12, 13, (14)	12.5
UOW-11-22	23.52	180	326	1.8	17, 19, 21, (22)	12.5
UOW-11-30	31.36	135	347	2.5	23, 24, 26, 28, (30)	12.5
SHUT OFF TYPE						
UOW-T60-10	3.9 - 12.7	300	370	1.8	8, 9, (10)	18.0
UOW-T60-14	4.9 - 16.7	230	385	2.2	10, 11, 12, 13, (14)	18.0
UOW-T60-22	6.9 - 23.5	170	400	2.2	17, 19, 21, (22)	18.0
UOW-T60-30	9.8 - 31.4	130	420	2.9	23, 24, 26, 28, (30)	18.0

In addition to listed sizes, other hex sizes are available for each model. Specify hex size when ordering otherwise the standard ratchet will be supplied. Max torque serves as a reference only.

	Air Inlet	Hose Bore
All models	1/4" NPT	10 mm



UOW-11-14



UOW-11-14

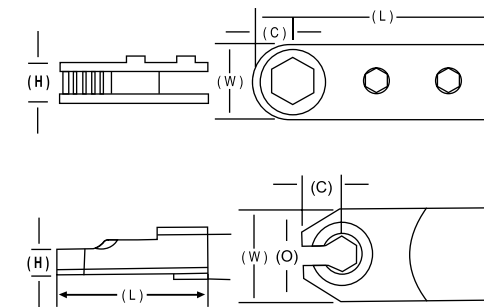

Model	H mm	W mm	L mm	C mm
URW-6	13.0	20.0	88.0	10.0
URW-8, 8N	18.0	25.0	102.5	12.5
URW-10N	18.0	33.0	106.5	16.5
URW-12N	18.0	36.0	109.5	18.0
URW-12NA	18.0	46.0	120.5	23.0
URW-12NB	18.0	54.0	128.5	27.0
UOW-11-10, UOW-T60-10	14.0	37.0	5.0 - 6.0	10.0
UOW-11-14, UOW-T60-14	14.0	40.0	6.0 - 9.0	13.0
UOW-11-22, UOW-T60-22	16.0	56.0	13.0 - 15.0	17.0
UOW-11-30, UOW-T60-30	16.0	68.0	15.0 - 23.0	21.0

RATCHET WRENCHES

Ratchet wrenches offer versatile service in driving and removing bolts or nuts in narrow access applications. Bent head, thin head and extended head type are available for hard-to-access fastening jobs.

Model	Capacity (nominal bolt size) mm	Torque Range Nm	Free Speed rpm	Overall Length mm	Weight kg	Hex Size () Standard mm	Average Air Cons. cfm
STALL TYPE							
URW-6	M6	10.78	200	292	1.15	7, 8, (10), 12	9.90
URW-8	M8	13.72	240	360	1.80	9, 10, 12, (14)	19.8
URW-8N	M8	15.68	220	300	1.80	9, 10, 12, (14)	19.5
URW-9N	M10	31.36	200	380	2.30	9, 10, 12, (14)	23.7
URW-10N	M10	56.84	150	394	2.65	12, 14, (17)	25.0
URW-12N	M13	58.80	150	397	2.70	19, (21)	25.0
URW-12NA	M14	78.40	100	408	3.00	22, (24), 27	25.0
URW-12NB	M16	93.10	85	416	3.20	29, (30), 32	25.0

In addition to listed sizes, other hex sizes are available for each model. Specify hex size when ordering otherwise the standard ratchet will be supplied. Max torque serves as a reference only.



URW-8N



URW-10N

SCREWDRIVERS

Ingersoll Rand dominates the industry with the most comprehensive range of pneumatic screwdrivers. Shut-off, slip & positive clutch models are offered in different speeds in straight, pistol grip and right angle configurations.

The auto shut off range is recommended for applications requiring torque consistency. Shut off tools also minimise component breakage during fastening of fragile plastic & bakelite components.

Auto start screwdrivers minimise operator fatigue, allow faster operations and reduce air consumption.

Right-angle screwdrivers have been designed for applications with limited access and are more comfortable on high torque applications.



1RPNS1/WI

41SA10PSQ4/WI

QS1L02S1

1RLNC1/WI

1RLN2S3/WI

Model	Torque Range Nm	Free Speed rpm	Overall Length mm	Body Diameter mm	Weight kg	Average Air Cons. cfm*
AUTO SHUT OFF SCREWDRIVERS						
Straight Handle						
Auto Start						
1RPLS1/WI	0.4 - 1.45	2800	-	28	0.50	1.6
1RPM51/WI	0.28 - 2.30	1650	223	28	0.50	1.6
1RPNS1/WI	0.17 - 3.40	1000	223	28	0.50	1.6
IRPQ51/WI	0.15 - 5.10	500	-	28	0.50	1.6
41SA17PSQ4/WI	1.70 - 7.00	1700	277	40	1.20	6.0
41SA10PSQ4/WI	1.70 - 9.00	1000	277	40	1.20	6.0
Lever Start						
QS1L10S1D	0.30 - 4.50	1000	241	44	0.70	3.2
QS1L02S1D	0.30 - 5.40	250	241	44	0.70	3.2
Pistol Type						
Auto Start						
QP1P10S1D	0.30 - 4.50	1000	224	30	0.84	3.2
QP1P05S1D	0.30 - 5.40	500	224	30	0.84	3.2
41PA16PSQ4/WI	1.70 - 6.80	1600	249	44	1.36	5.6
41PA8PSQ4/WI	1.70 - 11.30	800	249	44	1.36	5.6
Trigger Start						
QP1S10S1D	0.30 - 4.50	1000	224	30	0.84	3.2
41PA16TSQ4/WI	1.70 - 6.80	1600	249	44	1.36	5.6
41PA8TSQ4/WI	1.70 - 11.30	800	249	44	1.36	5.6
Trigger Permit						
1RTMS1/WI	0.28 - 2.30	1650	218	34	0.68	1.6
1RTNS1/WI	0.17 - 3.40	1000	218	34	0.68	1.6
1RTQ51/WI	0.17 - 5.10	500	223	34	0.68	1.6
Right Angle Screwdrivers						
1RLN2S3/WI	0.20 - 5.30	1/4 Hex	700	318	0.8	1.6
CUSHION CLUTCH SCREWDRIVERS						
Straight Handle						
Auto Start						
1RPNC1/WI	0.17 - 3.40	1000	223	28	0.48	1.6
1RPMC1/WI	0.28 - 2.30	1650	223	28	0.48	1.6
41SC17PSQ4/WI	1.10 - 6.80	1700	277	40	1.36	4.0
41SC10PSQ4/WI	1.10 - 9.00	1000	277	40	1.36	4.0
Lever Start						
1RLNC1/WI	1.70 - 3.40	1000	233	28	0.50	1.6
Pistol Type						
Trigger Start						
1RAMC1/WI	0.28 - 2.30	1650	218	34	0.68	1.6
1RANC1/WI	0.17 - 3.40	1000	218	34	0.68	1.6
Auto Start						
41PC16PSQ4/WI	1.70 - 6.80	1600	249	44	1.36	5.6
41PC8PSQ4/WI	1.70 - 11.30	800	249	44	1.36	5.6

20% of air consumption at full load.

41 series screwdrivers are also available with finder type bit holders.

	Air Inlet	Hose Bore
1	1/8" NPT	6 mm
41 & 7672	1/4" NPT	8 mm

	Air Inlet	Hose Bore
Q	1/4" NPT	6 mm
22 & 2	1/4" BSP	8 mm

QI IMPACT SCREWDRIVERS

Qi Series air impact screwdrivers are designed with the end user in mind. Best-in-class ergonomics allow the operator to focus on the job, not the tool, and the extremely durable impact mechanism delivers high speed reactionless power capable of meeting the rigorous demands of high cycle rate assembly applications.

The end result: a tool that helps you maximize productivity.



Model	Bolt Size Nm	Torque Range 90 psi Nm	Free Speed 90 psi rpm	Weight kg	Drive Size in
INLINE LEVER START					
QIS08Q4	M4	2 - 8	13,500	0.8	1/4"
QIS14Q4	M5	5 - 14	13,000	0.8	1/4"
QIS20Q4	M6	10 - 20	12,000	1.0	1/4"
QIS30Q4	M8	20 - 27	12,000	1.0	1/4"
PISTOL TRIGGER START					
QIP08Q4	M4	2 - 8	12,000	0.7	1/4"
QIP14Q4	M5	5 - 14	12,400	0.8	1/4"
QIP20Q4	M6	10 - 20	11,300	1.0	1/4"
QIP30Q4	M8	20 - 30	9,000	1.0	1/4"

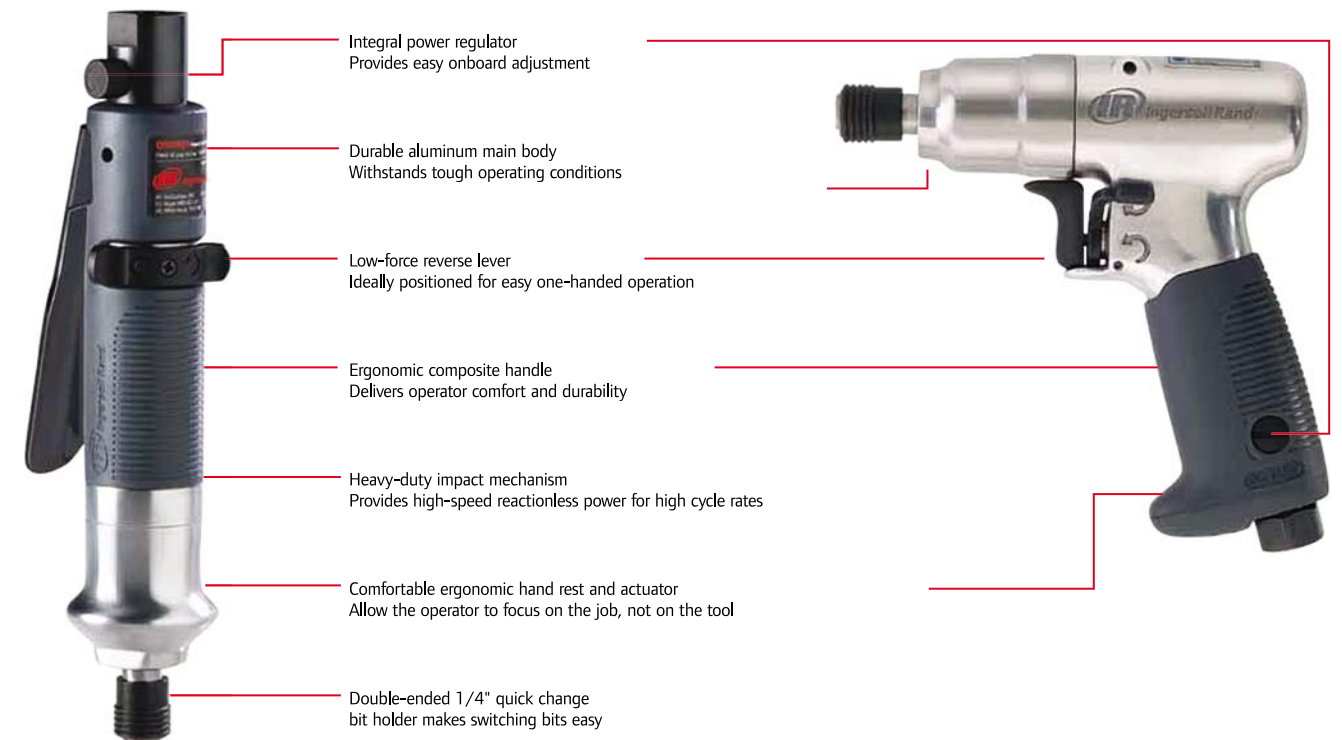

Performance figures are at 620 kPa (90 psi) air pressure

The Solution Providers | 19

IMPACT WRENCHES

Ingersoll Rand brings over 60 years of experience to impact wrench design and manufacturing. Ingersoll Rand impact tools are renowned world wide as the most reliable and tough tools available. The twin hammer mechanism developed by Ingersoll Rand provides unmatched durability and performance and has been the industry standard for several years.

Torque figures shown in the catalogue represent torque achieved under test conditions. Due to joint losses (see fig.) the actual torque achieved on a joint will vary. It is therefore recommended that impact wrenches be selected after actual trials wherever possible.

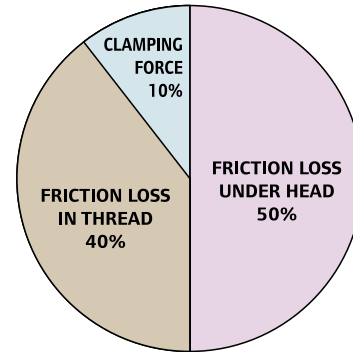

Twin Hammer (T)



Jumbo Hammer (J)



212/WI



IR 2115 TiMAX



IR 2135TiMAX



IR2190Ti

2015 MAX / 2025 MAX

Model	Drive in	Handle	rpm	Max. Torque kg	Torque Range (Recommended)		Weight kg	Size Hose Recomm. mm
					min	max		
211/WI	3/8" Sq.	S	10000	203	27	170	1.09	10
212/WI	3/8" Sq.	P	10200	244	27	170	1.3	10
211R2/WI	1/2" Sq.	S	10000	203	27	170	1.09	10
212R2/WI	1/2" Sq.	P	10200	244	27	170	1.3	10
2115TiMAX	3/8" Sq.	P	15000	407	34	312	1.12	10
2115PTiMAX	3/8" Sq.	P	15000	407	34	312	1.1	10
2115QTiMAX	3/8" Sq.	P	15000	407	34	312	1.13	10
2135PTiMAX	1/2" Sq.	P	9800	1054	68	746	1.79	10
2135QTiMAX	1/2" Sq.	P	9800	1054	68	746	1.82	10
2125QTiMAX	1/2" Sq.	P	15000	450	34	340	1.14	10
2125PTiMAX	1/2" Sq.	P	15000	450	34	340	1.14	10
231C	1/2" Sq.	P	8000	813	34	407	2.63	10
259	3/4" Sq.	P	6000	1427	271	1085	4	10
2145QiMAX	3/4" Sq.	P	7000	1830	271	1220	3.4	13
2155QiMAX	1" Sq.	P	7000	1830	271	1220	3.4	13
2190Ti	1" Sq.	Grip I.T	6800	2237	204	1360	6.4	13
231HA	1/2" Sq.	P	8000	800	34	407	2.63	10
285B	1" Sq.	Grip I.T	5000	2000	136	1220	11.43	13
2015 Max	3/8" Sq.	Angle	7,100	244	61-217	61-190	1.54	10
2025 Max	1/2" Sq.	Angle	7,100	244	61-217	61-190	1.54	10

• P = Pistol • S = Straight

EXTENDED ANVILS AVAILABLE

2"	6"
231H	285B
2135TiMAX*	2190Ti

• Tools of 2½" & 3½" square drives also available, Max torque range 108,500 Nm.
Reverse bias tools, develop higher torque in reverse for opening stubborn fasteners.

Model	Air Inlet	Hose Bore
259	3/8"	10 mm
285B, 2145, 2155 & 2190Ti	1/2"	13 mm
All other models	1/4"	10 mm

FASTENING COUNTER

Ingersoll Rand fastening counter model FPY-1100 is a pokayoke solution for tightening a preset number of fasteners. The unit counts down the number of bolts or nuts fastened by oil-pulse tools or screwdrivers modified to sense the back pressure from these tools. This function automatically makes sure of correct fastening of the specified number of bolts or nuts. A clear LED display, go/no lights and buzzer help avoid human errors and common fastening mistakes. Can also be used with click type torque wrenches. Screwdrivers & nut runners.



Oil pulse tools or impact wrenches to be used with FPY-1100 must be modified to sense air signal through exhaust outlet.

PLEASE SPECIFY "TM MODEL" WHEN ORDERING THE TOOL e.g. UX-700 (TM)

QC AIR TOOL QUALIFIER

Process Qualification

- Provides OK/NOK signal based on air flow rundown signature.
- Verifies batch/gang count and cycle time completion.
- Stores two (2) parameter sets for different joint applications.
- Optional hose light gives operator visual feedback right at the tool.
- Total cycle count alarm indicates when preventive maintenance is required.

Error-Proofing

- Detects rehits, cross-threads, and early throttle release.

Easy Setup

- Quickly leads you through the setup procedure with simple menu prompts.
- Process Flow Control and Alarms.
- I/O standard. Can interface with alarms or process control devices.

Shutoff Capability

- Solenoid Valve provides shutoff tools.

Tool Compatibility

- No tool modification required (such as special valves, or porting).
- Works with shut off & standard Pulse tools, impacts 3/8" & ½" Sq. dr. tool & QA 4 nutrunners (Not compatible with QA6 & QA8 Series of nutrunner)

Model	Tool Compatibility
QC 100-S-K	Non shut off pulse tools, 3/8" & ½" impact tools
QC 200-S-K	Shut off pulse tools, QA 4 clutch shut off nutrunners



EXTA SERIES EXPERT TORQUE ANALYSER



The new Ingersoll Rand EXTA series torque analyser is designed for use with an extensive new range of transducers to measure and record the torque output of all types of fastening tools, including pulse wrenches.

The EXTA torque analyser has full statistical capability, and data can be downloaded to a computer or printer via RS-232 port. A full line of joint-kits facilitates testing of fastening tools in the tool crib, quality lab or on the line. The EXTA is portable and is capable of reading in four different modes to cover a variety of tools such as standard air tools, pulse tools and click wrenches.

- Monitors torque, angle, time and pulse count
- Reads in peak, click, pulse, or track mode
- Stores 200 time-stamped readings
- Auto-recognition of Smart transducers
- Seven units of measure
- Selectable filter frequencies
- DC tool calibration via ICS software
- Selectable power-save settings
- Selectable languages include English, French, German, Italian and Spanish

TYPICAL SCREEN

Number of pulses (pulse mode only) → 9

Torque reading → 24.18 Nm

Tightening direction → [Symbol]

Transducer information → [Symbol]

Total time torque is applied (cycle time) → 2.970

Cycle end time → 0.136

Filter frequency → 1536 Hz

Press the corresponding number on the keypad to access the features displayed on the bottom row of the screen.



ROTARY TRANSDUCERS FOR USE WITH EXTA

Drive Size	Transducer Range	Rotary* Transducer (Torque)	Smart Series Torque & Angle
Nm			
1/4" Hex	0.10 - 2	TR2H4	—
1/4" Square*	1.0 - 20	TR20S4	TRDA20S4
3/8" Square	3.8 - 75	TR75S6	TRDA75S4
1/2" Square	9.0 - 180	TR180S8	TRDA180S8
3/4" Square	25.0 - 500	TR500S12	TRDA500S12

* Requires cable for connection EXTA-TC Not recommended for Impact Tools

BENCH TOP JOINT SIMULATORS FOR ROTARY TRANSDUCERS

Drive Size	Joint Capacity	Joint Simulator
1/4" Square	20	JKR20
3/8" Square	75	JKR75
1/2" Square	180	JKR180
3/4" Square	500	JKR500

- 1/4 Hex Size also available.
- Stationary transducers from 1.5 to 1000 Nm are available.
- Additional models for rotary transducers available.

TORQUE WRENCHES / TESTERS

"Ingersoll Rand represents in India, Tohnichi of Japan for their extensive range of torque auditing equipment. This includes a large range of click and dial type torque wrenches including wrenches fitted with special heads and attachments"

QL/QLE

Ratchet Head Type Adjustable Torque Wrench



- Basic adjustable click style with resin grip
- Torque value easily set with external scale and knob

Model	Tourqe Range		Metric Model	Tourqe Range		American Model	Tourqe Range		Overall Length	Square Drive	Weight
	Min.-Max. Nm	Grade Nm		Min.-Max. kgf.cm	Grade kgf.cm		Min.-Max. lbf.in	Grade lbf.in			
QL1.5N4	0.3-1.5	0.01	15QL4	3-15	0.1	15QL4-A	3-15	0.1	160	6.35	0.16
QL3N4	0.6-3	0.02	30QL4	6-30	0.2	30QL4-A	6-30	0.2	160	6.35	0.16
QL6N4	1-6	0.05	60QL4	10-60	0.5	QL50I-2A	10-50	0.5	195	6.35	0.19
QL12N4	2-12	0.1	120QL4	20-120	1	QL100I-2A	20-100	1	195	6.35	0.25
QL25N	5-25	0.25	225QL4	50-250	2.5	QL200I-3A	50-200	2.5	230	9.53	0.25
QL50N	10-50	0.5	450QL4	100-500	5	QL400I-3A	100-400	5	260	9.53	0.45
-	-	-	-	-	-	QL750I-3A	150-750	10	335	9.53	0.69
-	-	-	-	-	-	-	lbf-ft	lbf-ft	-	-	-
-	-	-	-	-	-	QL750F-3A	15-75	1	335	9.53	0.69
QL100N4	20-100	1	900QL4	200-1000	10	-	-	-	335	12.7	0.69
QL140N	30-140	1	1400QL3	300-1400	10	QL100F-4A	30-100	1	400	12.7	0.88
QL200N4	40-200	2	1800QL4	400-2000	20	QL150F-4A	30-150	2	490	12.7	1.4
-	-	-	-	kgf.m	kgf.m	-	-	-	-	-	-
QL280N	40-280	2	2800QL3	4-28	0.2	-	-	-	695	19.05	2.0
QL420N	60-420	2	4200QL2	6-42	0.2	QL300F-6A	60-300	2	995	19.05	3.4
QLE550N	100-550	5	5500QLE	10-55	0.5	QL400F-6A	100-400	5	1195	19.05	5.1
QLE750N	100-750	5	7500QLE	10-75	0.5	QL600F-6A	100-600	5	1370	19.05	7.1
QLE1000N	100-1000	5	10000QLE	10-100	0.5	QL700F-8A	100-700	5	1540	25.4	9.5
QLE1400N	200-1400	10	14000QLE	20-140	1	QL1000F-8A	150-1000	10	1795	25.4	13.1
QLE2100N	500-2100	20	21000QLE	50-210	2	QL1500F-8A	600-1500	20	1950	25.4	20.0

QSP

Ratchet Head Type Preset Torque Wrench



- No external scale, Torque value set using key & tester
- Ideal for mass production application

Model	Tourqe Range Min.-Max. Nm	Tourqe Range Min.-Max. kgf.cm	Tourqe Range Min.-Max. lbf.in	Overall Length mm	Square Drive mm	Weight (g)
QSP1.5N4	0.3 - 1.5	3-15	3-13	165	6.35	0.16
QSP3N4	0.6 - 3	6-30	6-25	165	6.35	0.16
QSP6N4	1-6	10-60	10-50	165	6.35	0.19
QSP12N4	2-12	20-120	20-100	175	6.35	0.25
QSP25N3	5-25	50-250	50-200	215	9.53	0.25
QSP50N3	10-50	100-500	100-400	240	9.53	0.4
QSP100N4	20-100	200-1000	-	315	12.7	0.65
QSP140N3	30-140	300-1400	300-1000	380	12.7	0.7
QSP200N4	40-200	400-2000	350-1600	465	12.7	1.2
-	-	kgf.m	-	-	-	-
QSP280N3	40-280	4-28	350-2500	665	19.05	1.8
QSP420N3	60-420	6-42	600-3600	970	19.05	3.1

SP/SP-MH/RSP

Open End/Ring Head Type Preset Torque Wrench

- Various sizes of open end or ring heads fixed on wrench
- Ideal for specific bolt size application



SP38N x 10

Model (Body Size x Width)		Torque Range		Head Dimension		Overall Length mm	Weight (g)
SP	SP-MH	Min.-Max. Nm	Grade Nm	O.W. x Thickness mm	Overall Length mm		
SP2Nx5.5	-	0.4-2	4-20	23 x 5	180	0.15	
SP2Nx7	-	0.4-2	4-20	23 x 5	180	0.15	
SP2Nx8	-	0.4-2	4-20	23 x 5	180	0.15	
SP2Nx10	-	0.4-2	4-20	23 x 5	180	0.15	
SP2Nx12	-	0.4-2	4-20	23 x 5.5	180	0.15	
SP2Nx13	-	0.4-2	4-20	23 x 5.5	185	0.15	
SP2Nx17	-	0.4-2	4-20	28 x 6	190	0.15	
SP2Nx19	-	0.4-2	4-20	29 x 8	195	0.15	
SP8Nx7	-	1.5-8	15-80	23 x 5	180	0.15	
SP8Nx8	-	1.5-8	15-80	23 x 5	180	0.15	
SP8Nx9	-	1.5-8	15-80	23 x 5	180	0.15	
SP8Nx10	-	1.5-8	15-80	23 x 5	180	0.15	
SP8Nx12	-	1.5-8	15-80	25 x 5.5	180	0.15	
SP8Nx13	-	1.5-8	15-80	25 x 5.5	185	0.15	
SP8Nx19	-	1.5-8	15-80	29 x 8	185	0.15	
SP8Nx24	-	1.5-8	15-80	34 x 8	195	0.15	
SP8Nx27	-	1.5-8	15-80	40 x 8	200	0.15	
SP19Nx10	SP19Nx10-MH	3.5-19	35-190	27 x 6.5	210(206)	0.20	
SP19Nx11	SP19Nx11-MH	3.5-19	35-190	27 x 6.5	210(206)	0.20	
SP19Nx12	SP19Nx12-MH	3.5-19	35-190	30 x 6.5	210(206)	0.20	
SP19Nx13	SP19Nx13-MH	3.5-19	35-190	30 x 6.5	210(206)	0.20	
SP19Nx14	SP19Nx14-MH	3.5-19	35-190	30 x 6.5	210(206)	0.20	
SP19Nx17	SP19Nx17-MH	3.5-19	35-190	31 x 8	210(206)	0.20	
SP19Nx19	SP19Nx19-MH	3.5-19	35-190	33 x 8	220(206)	0.20	
SP19Nx21	SP19Nx21-MH	3.5-19	35-190	35 x 8	220(206)	0.20	
SP19N-1x10	SP19N-1x10-MH	3.5-19	35-190	24x12	215(211)	0.20	
SP19N-2x10	SP19N-2x10-MH	3.5-19	35-190	24x20	215(211)	0.20	
SP19N-3x10	SP19N-3x10-MH	3.5-19	35-190	24x15	215(211)	0.20	
SP38Nx8	SP38Nx8-MH	8-38	80-380	31x8	250(245)	0.35	
SP38Nx9	SP38Nx9-MH	8-38	80-380	31x8	255(250)	0.35	
SP38Nx10	SP38Nx10-MH	8-38	80-380	31x8	255(250)	0.35	
SP38Nx11	SP38Nx11-MH	8-38	80-380	35x8	250(245)	0.35	
SP38Nx12	SP38Nx12-MH	8-38	80-380	35x8	255(250)	0.35	
SP38Nx13	SP38Nx13-MH	8-38	80-380	35x8	255(250)	0.35	
SP38Nx14	SP38Nx14-MH	8-38	80-380	35x8	255(250)	0.35	
SP38Nx16	SP38Nx16-MH	8-38	80-380	38x8	255(250)	0.35	
SP38Nx17	SP38Nx17-MH	8-38	80-380	38x8	255(250)	0.35	
SP38Nx19	SP38Nx19-MH	8-38	80-380	38x8	255(250)	0.35	
SP38Nx22	SP38Nx22-MH	8-38	80-380	41x8	255(250)	0.35	
SP38Nx24	SP38Nx24-MH	8-38	80-380	43x8	270(265)	0.35	
SP38Nx27	SP38Nx27-MH	8-38	80-380	45x8	270(265)	0.35	

Model (Body Size x Width)		Torque Range		Head Dimension		Overall Length mm	Weight (g)
SP	SP-MH	Min.-Max. Nm	Grade Nm	O.W. x Thickness mm	Overall Length mm		
SP38N-1x10	SP38N-1x10-MH	8-38	80-380	24x12	250(245)	0.35	
SP38N-2x10	SP38N-2x10-MH	8-38	80-380	25x20	250(245)	0.35	
SP38N-3x10	SP38N-3x10-MH	8-38	80-380	24x15	250(245)	0.35	
SP67Nx14	-	13-67	130-670	45x10	320	0.5	
SP67Nx16	-	13-67	130-670	45x10	320	0.5	
SP67Nx17	-	13-67	130-670	45x10	320	0.5	
SP67Nx18	-	13-67	130-670	45x10	320	0.5	
SP67Nx19	-	13-67	130-670	45x10	320	0.5	
SP67Nx21	-	13-67	130-670	45x10	325	0.5	
SP67Nx22	-	13-67	130-670	45x10	325	0.5	
SP67Nx24	-	13-67	130-670	46x11	330	0.5	
SP67Nx27	-	13-67	130-670	50x11	330	0.5	
SP67Nx29	-	13-67	130-670	50x11	330	0.5	
SP67Nx30	-	13-67	130-670	52x11	335	0.5	
SP67Nx32	-	13-67	130-670	54x11	335	0.5	
SP67Nx33.3	-	13-67	130-670	57x11	335	0.5	
SP120Nx14	-	24-120	240-1200	45x11	390	0.75	
SP120Nx17	-	24-120	240-1200	45x11	390	0.75	
SP120Nx18	-	24-120	240-1200	51x11	395	0.75	
SP120Nx19	-	24-120	240-1200	51x11	395	0.75	
SP120Nx21	-	24-120	240-1200	51x11	395	0.75	
SP120Nx22	-	24-120	240-1200	51x11	395	0.75	
SP120Nx23	-	24-120	240-1200	51x11	395	0.75	
SP120Nx24	-	24-120	240-1200	51x11	395	0.75	
SP120Nx27	-	24-120	240-1200	53x15	400	0.75	
SP120Nx30	-	24-120	240-1200	56x15	400	0.75	
SP160Nx19	-	30-160	300-1600	52x13	440	0.95	
SP160Nx21	-	30-160	300-1600	52x13	440	0.95	
SP160Nx22	-	30-160	300-1600	56x13	440	0.95	
SP160Nx24	-	30-160	300-1600	56x13	445	0.95	
SP160Nx26	-	30-160	300-1600	56x13	445	0.95	
SP160Nx41	-	30-160	300-1600	70x15	445	0.95	
SP220Nx19	-	45-220	450-2200	60x15	580	1.44	
SP220Nx22	-	45-220	450-2200	60x15	580	1.44	
SP220Nx24	-	45-220	450-2200	65 x15	580	1.4	
SP220Nx27	-	45-220	450-2200	65 x15	580	1.4	
SP220Nx29	-	45-220	450-2200	65 x15	585	1.4	
SP220Nx30	-	45-220	450-2200	63 x15	585	1.4	
SP220Nx32	-	45-220	450-2200	65 x15	585	1.4	
SP220Nx34	-	45-220	450-2200	63 x15	585	1.4	
SP220Nx36	-	45-220	450-2200	67 x15	590	1.4	
SP220Nx36	-	45-220	450-2200	72 x15	590	1.4	

CPT

PRO TORK (Digital Tightening Torque Wrench)

- Highly responsive to the applied torque value with indicator display
- Equipped with bright LED lamp
- Data Memory and Torque Set Registration



CPT50x12D-G

Model	Torque Range		Torque Range		Torque Range		Torque Range		Torque Range		Overall Length mm	Weight (kg)
	Min.-Max. Nm	Grade Nm	Min.-Max. kgf.cm	Grade kgf.cm	Min.-Max. kgf.m	Grade kgf.m	Min.-Max. lbf.in	Grade lbf.in	Min.-Max. lbf.ft	Grade lbf.ft		
CPT20x10D-G	4-20	0.02	40-200	0.2	0.4-2	0.002	36-180	0.2	3-14.5	0.02	280.5	0.63
CPT20x12D-G	10-50	0.05	100-500	0.5	1-5	0.005	100-450	0.5	7.5-36	0.05	282.5	0.65
CPT100x15D-G	20-100	0.1	200-1000	1	2-10	0.01	200-880	1	15-73	0.1	384.5	0.85
CPT200x19D	40-200	0.2	400-2000	2	4-20	0.02	360-1700	0.2	30-150	0.2	475.5	1.37
CPT280x22D	58-280	0.2	560-2800	2	5.6-28	0.02	500-2400	0.2	42-200	0.2	591.5	1.76

FH256MC

Radio Frequency Torque Wrench System

- Wireless error-proofing (Pokayake) torque system
- FHSS technology with universal 2.4 GHz frequency band
- Wrench ID transfer functions to establish bolt tightening traceability
- Easily change frequency with wireless setting box (optional)



QLFH100N4



T-FH256MC



R-FH256



SB-FH256



I/O-FH256

FH Torque Wrench Examples

QLFH

FH transmitter mounted on QL

Model
QLFH25N
QLFH50N
QLFH100N4
QLFH140N
QLFH200N4

SPFH

FH transmitter mounted on SP

Model
SPFH38Nx14
SPFH38Nx27

TRANSMITTER

All kinds of frequency groups (256 kinds) can be set in one transmitter.

Model	Description
T-FH256MC	Transmitter for FH256MC
T-FH256MC-LS	Transmitter for LS type wrench

Note : T-FH256MC-LS is a wireless transmitter module to install on LS version torque wrenches.

RECEIVER

All kinds of frequency groups (256 kinds) can be set in one receiver.

Model	Specification
R-FH256	Output : No-Voltage contact output (1a) RS232C
R-FH256	Size : W150 x D210 x H51 (mm), Weight 1.7 kg
R-FH256	Power : AC100V-24V, 47-63Hz

Standard Accessories : Dipole antenna

SETTING BOX

Wireless setting device for FH transmitter and receiver.

Model	Specification
SB-FH256	Input: RS232C, Power : DC9V

Standard Accessories : Dipole antenna

MULTI I/O BOX

Manage 4 tightening signals from receiver and output to external device.

Model	Applicable Model	Specification
I/O-FH256	R-FH256	Output : No-Voltage Contact output (1a) x 4 Power : AC 100-240V

CNA-4mk2

POKA Patrol (Count Checker)

- Torque tightening verification counter
- Manages signals from LS of FH torque wrenches
- Up to 4 wrenches can be controlled at one time (in succession)



Model	CNA-4mk2
Count Display	2 digits, 7 segments, LED
Judgment Function	Domed shaped Lamp (OK/NG)
Count Input	Cable terminals x 4
Maximum Preset Counter	99
Work Setting Availability	4 sets max.
Judgement Output	OK : Green Lamp NG : Red Lamp + buzzer (4 patterns)
Mode Exchange Setting	Normal mode Multiple mode (maximum 4 torque wrenches cab be connected)
Electric Power Supply	Ac100-240V 50/60 Hz
Size and Weight	W150 mm x D210mm x H51 mm, 1.5 kg

DB/DBE/DBR

Dial Indicating Torque Wrench

- Memory pointer for easy torque reading
- Ideal for torque measuring and quality check application



Model	Torque Range		Metric Model	Torque Range		American Model	Torque Range		Overall Length	Square Drive	Weight
	Min.-Max. Nm	Grade Nm		Min.-Max. kgf.cm	Grade kgf.cm		Min.-Max. lbf.in	Grade lbf.in			
DB1.5NA4-S	0.2-1.5	0.02	15DB4-S	2-15	0.2	DB131-2AS	0-13	0.2	205	6.35	0.4
DB3N4-S	0.3-3	0.05	30DB4-S	3-30	0.5	DB261-2AS	0-26	0.5	205	6.35	0.4
DB6N4-S	0.6-6	0.1	60DB4-S	6-60	1	DB401-2AS	0-40	0.5	205	6.35	0.4
DB12N4-S	1-12	0.2	120DB4-S	10-120	2	DB751-2AS	0-75	1	205	6.35	0.4
DB25N-S	3-25	0.5	230DB3-S	30-250	5	DB1501-3AS	0-150	2	245	9.5	0.6
DB50N-S	5-50	0.5	450DB3-S	50-500	5	DB3001-3AS	0-300	5	320	9.5	0.6
DB100N-S	10-100	1	900DB3-S	100-1000	10	DB6001-4AS	0-600	10	400	12.5	0.7
-	-	-	-	-	-	-	-	-	-	-	-
-	-	-	-	-	-	DB25F-3AS	0-25	0.5	320	9.5	0.6
-	-	-	-	-	-	DB50F-3AS	0-50	0.5	400	9.5	0.7
-	-	-	-	-	-	DB50F-4AS	0-50	0.5	400	12.7	1.0
DB200N-S	20-200	2	1800DB3-S	200-2000	20	DB100F-4AS	0-100	1	500	12.7	1.0

CEM3

DATA TORK (Digital Torque Wrench)

- Dual LED & LCD displays for optimal viewing
- 999 memory storage capacity
- For inspection and tightening



Model	Torque Range		Torque Range		Torque Range		Torque Range		Torque Range		Hand Force N	Overall Length mm	Weight kg
	Min.-Max. Nm	1 digit Nm	Min.-Max. kgf.cm	1 digit kgf.cm	Min.-Max. kgf.m	1 digit kgf.m	Min.-Max. lbf.in	1 digit lbf.in	Min.-Max. lbf.ft	1 digit lbf.ft			
CEM10N3x8D-G	2-10	0.01	20-100	0.1	0.200-1	0.001	20-90	0.1	1.50-7.3	0.01	48.1	212	0.46
CEM20N3x10D-G	4-20	0.02	40-200	0.2	0.400-2	0.002	36-180	0.2	3-14.5	0.02	92.2	214	0.47
CEM50N3x12D-G	10-50	0.05	100-500	0.5	1-5	0.005	100-440	0.5	7.5-36	0.05	196.9	282	0.58
CEM100N3x15D-G	20-100	0.1	200-1000	1	2-10	0.01	200-880	1	15-73	0.1	275.5	384	0.63
CEM200N3x19D-G	40-200	0.2	400-2000	2	4-20	0.02	360-1700	2	30-150	0.2	428.3	475	0.78
CEM360N3x22D-G	72-360	0.4	720-3600	4	7.20-36	0.04	650-3100	4	52-260	0.4	498.6	713	1.13
CEM500N3x22D-G	100-500	0.5	1000-5000	5	10-50	0.05	890-4400	5	73-360	0.5	549.5	949	4.00
CEM850N3x32D-G	170-850	1	-	-	17-85	0.1	-	-	124-620	1	608	1387	5.14

DOE3-G

Digital Torque Wrench Tester

- Multiple units of measure through keypad setup.
- "Loading system" stabilizes wrench during calibration procedure for optimal results.
- RS232C Output.
- Mx. 99 measured data can be stored.



Model	Torque Range		Torque Range		Torque Range		Torque Range		Torque Range		Torque Range		Torque Wrench Max. Effective Length mm	Inlet Drive mm	Weight kg
	Min.-Max. cNm	1 digit cNm	Min.-Max. Nm	1 digit Nm	Min.-Max. kgf.cm	1 digit kgf.cm	Min.-Max. kgf.m	1 digit kgf.m	Min.-Max. lbf.in	1 digit lbf.in	Min.-Max. lbf.ft	1 digit lbf.ft			
DOE20N3-G	200-2000	0.5	2-20	0.005	20-200	0.05	-	-	18-180	0.05	-	-	410	9.5	11
DOE50N3-G	-	-	5-50	0.01	50-500	0.1	-	-	44-440	0.1	3.60-36	0.01	410	9.5	11
DOE100N3-G	-	-	10-100	0.021	100-1000	0.2	-	-	88-880	0.2	7.30-73	0.02	410	12.7	11
DOE200N3-G	-	-	20-200	0.05	200-2000	0.5	-	-	170-1700	0.5	15-150	0.05	660	12.7	13

Ingersoll Rand's Other Products Solutions

ARO FLUID PRODUCTS

Our fluid products provide the industry-leading ARO brand air operated diaphragm and piston pumps for a broad spectrum of fluid transfer applications. Also count on us for high quality pneumatic valves, cylinders, motion control components and FRLs. The focus is on reducing downtime and increasing return on investment by extending the life of your equipment and improving productivity.

ARO Diaphragm Pumps

- Patented "unstallable" air valve and "quick-dump" exhaust valves allow for ice-free operation and maximum operating efficiency
- Multiple materials of construction for chemical compatibility and flow rates ranging from 17.4-1,041 L/min (4.6-275 gpm)



ARO Piston Pumps & Packages

- Pumps for fluid viscosities ranging from 500-1,000,000 cPs including oils, paints, inks, sealants, caulking & more
- Multiple package seal options, including leather, UHMW-PE and PTFE for chemical compatibility
- Optional Ultra-Coating for tubes and plungers reduces abrasion and scoring



ARO Lubrication Equipment

- Piston and diaphragm pumps and packages specifically designed to handle all types of oil, grease, and specialty-type fluid applications
- Specialty pumps for antifreeze/water mixing, solvents transfer, calcium chloride tire fill and high-pressure wash
- Diaphragm pumps meet U.L. 79 specification code for fuel related applications



ARO Filters, Regulators & Lubricators (FRL's)

- Best-in-class air flow with flow rates from 0.9-50 m³/min (32-1,770 scfm)
- Modular design for 1000 – 3000 series facilitates easy installation and maintenance
- Positive thumb-locking switch on polycarbonate bowls for enhanced safety



ARO Pneumatic Valves & Cylinders

- Valves with flow rates up to 7.8 Cv (280 scfm) and cylinders with stroke lengths up to 250 mm (9.9")
- 2-, 3- and 4-way valves with electrical, manual, mechanical & pneumatic actuators and various body styles to fit all applications
- NFPA interchangeable, round repairable and disposable, square and round compact cylinders to accommodate different environments



MATERIAL HANDLING

Ingersoll Rand has been serving the material handling needs of the toughest industries around the globe for nearly a century. We apply R&D expertise to introduce new products and technologies which integrate the latest electronics and controls. By using Ingersoll Rand solutions you can expect improved productivity and operator performance as well as reduced downtime.

Air, Electric & Hydraulic Utility Winches

- Available in a wide range of capacities from 300-10,000 kg (660-22,000 lbs)
- Top reliability with our Liftstar®, Pullstar®, BU, EU, Force 5® Third Generation and Infinity winch series
- Lifting, pulling and positioning applications for the world's toughest industries



ManRider Winches

- Available in capacities from 150-3,125 kg (330-6,875 lbs)
- LS2-150RLP, FA150KGi, Force 5® Third Generation and Infinity winch series ensure your personnel gets lifted safely
- Meeting the toughest personnel lifting requirements in the offshore industry



Balancers & Air, Electric & Hydraulic Hoists

- Balancers, CLK, MLK, HLK, ARO, Quantum, Liftchain®, Herculink® and BOP Handling Systems that can handle load capacities from 0.12-200 tons
- Air balancers with float to position load by hand for precision spotting
- Hoists for high-speed production, food grade applications and the harshest industrial, underground and marine environments



Manual Hoists

- Manual and lever chain hoists from 0.5-25 ton capacity
- Overload protection to reduce downtime and repair costs
- Versatility to be used in construction, maintenance and rigging applications



Workstation Bridge & Jib Cranes (Support Structures)

- Overhead and floor supported enclosed track workstation cranes with <1% rolling resistance and articulation for maximum ease of use
- Standard low profile enclosed track rail jib cranes with 220 and 360 degree coverage
- Standard and custom applications with bridge cranes up to 1,360 kg (3,000 lbs) and jib cranes up to 907 kg (2,000 lbs)



Handling Devices

- Custom and standard solutions and devices including clamping, vacuum, probing rotary action handlers and hook/trap action to overcome your material handling challenges
- Vacuum load capacities from 27-136 kg (60-300 lbs) and clamp load capacities from 27-45 kg (60-100 lbs)



ARO – Three letters. 80 years. One goal.

Safety is Our top priority.



Ingersoll Rand (NYSE:IR) advances the quality of life by creating and sustaining safe, comfortable and efficient environments. Our people and our family of brands—including Club Car®, Ingersoll Rand®, Schlage®, Thermo King® and Trane®—work together to enhance the quality and comfort of air in homes and buildings, transport and protect food and perishables, secure homes and commercial properties, and increase industrial productivity and efficiency. Ingersoll Rand products range from complete compressed air systems, tools and pumps to material handling systems. The diverse and innovative products, services and solutions enhance our customers' energy efficiency, productivity and operations. Ingersoll Rand is a \$14 billion global business committed to a world of sustainable progress and enduring results.



Ingersoll Rand Industrial Products (P) Ltd.

37-A, Site IV Sahibabad Industrial Area, Ghaziabad - 201010

Phone : (0120) 438 9200 / 438 9400

Fax : (0120) 438 9444

E-mail : airsolutionsindia@irco.com

www.ingersollrandproducts.com

www.ingersollrand.co.in

Customer Support Center 1-800-102-7926

customersupportindia@irco.com

Regional Offices' Phone Numbers

WEST Mumbai : (022) 61540500, Nagpur/Raipur : (0712) 2533697/2533386, Pune : (020) 41005400,
Surat : (0261) 2350064/3917335, Indore : (0731) 2435622

EAST Kolkata : (033) 24011224/24014258, Jamshedpur : (0657) 2233128/129

SOUTH Bangalore, Karnataka : (080) 22166001, Chennai, TN & Kerala : (044) 28523362/28520900,
Coimbatore : (0) 9344601020, Secunderabad, AP : (040) 27849813/16/24

NORTH Chandigarh : (0172) 3247151/2664334, Gurgaon : (0124) 6729000, Haridwar : (0) 9358631990

Ingersoll Rand, IR and the IR logo are trademarks of Ingersoll Rand, its subsidiaries and/or affiliates.

Nothing contained within this brochure is intended to extend any warranty or representation, expressed or implied, regarding the products described herein. Any such warranties or other items or conditions of sale of products shall be in accordance with Ingersoll Rand's standard terms and conditions of sale for such products, which are available upon request. Product improvement is a continuing goal at Ingersoll Rand. Designs and specifications are subject to change without notice or obligation.